

# NL Series

CNC Turning Centers

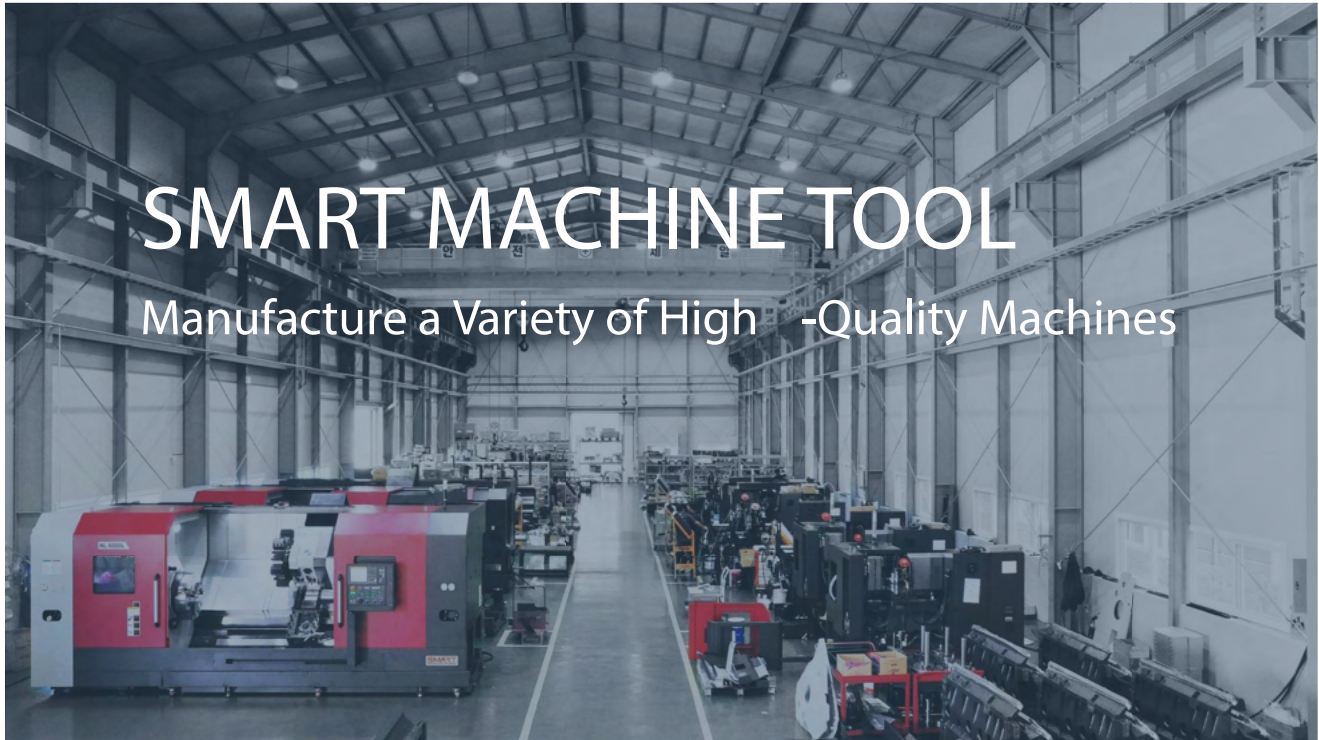



# SMART MACHINE TOOL

Manufacture a Variety of High -Quality Machines

2

*Smart Machine Tool produces machine tools based on the team's knowledge of product design, engineering and understanding what the market needs.*





### **Smart Machine Tool Korea**

With over 100 years of combined experience in the machine tool industry, Jong B. Won, Jong C. Kim, and Jong W. Shin were the original members of Samsung Machine Tools before starting Smart Machine Tool Korea. They are shareholders of Smart Machine Tool Korea and serve as CEO, the Head of Manufacturing, and the Head of Engineering and Design, respectively. Brian Whang started at Hyundai in 1993 and has spent the past 20 years in sales and finance at Dynamic International. He is a lawyer and CPA and serves as CFO for Smart Machine Tool Korea. Richard Layo, the owner of Dynamic International, started a Wisconsin based dealership in 1986, and started importing high-end CNC machine tools in 1999 from Japan, Korea, Taiwan and Smart Machine tool Korea and serves as Chairman.



# Smart Machine Construction

## Headstock

Radiator fan-like pin tube rib design dissipates heat generated by axis movements, maintaining minimum thermal expansion.



## Pre-Tension and Double Anchored Ballscrews

All axes ballscrews are pre-tensioned, heat treated and fixed by doubled anchors on both ends, providing ultimate rigidity and minimal thermal growth.



## Spindle

Double row cylindrical roller bearings and angular thrust bearing, ensure high rigidity for heavy cutting and excellent surface finishes.

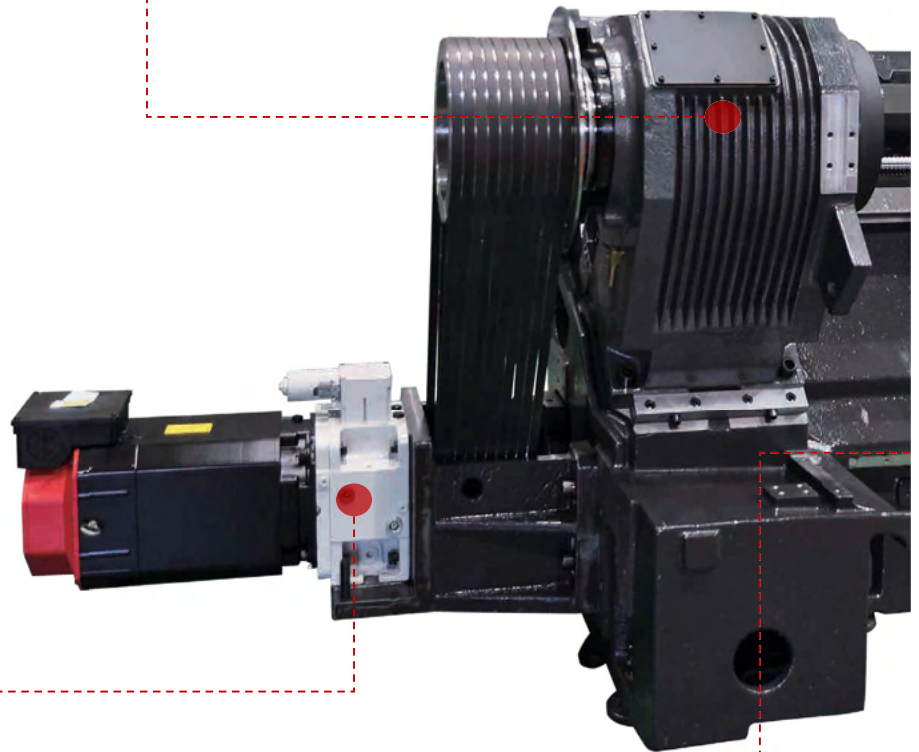
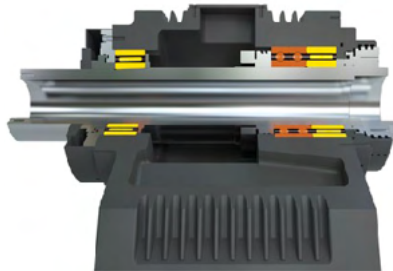

## Gearbox

NL 2500, 3000, 4000, 5000, 6000 are equipped with two-speed in-line gearbox provide machining stability and increase torque at low speed.



NL 2500, 3000 gearbox



NL 4000, 5000, 6000 gearbox

## Rigid 45 Degree Slant Bed

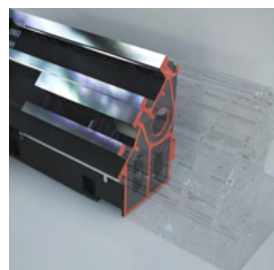

The 45 degree slant torque tube design bed and wide guide slide ways

Easy access to the workpiece and superb chip discharge.

### 12-Station Turret

Large diameter 3-piece Curvic coupling for excellent rigidity and extended tool life.

High torque AC servo motor driven for fast indexing time and excellent positioning and repeatability.

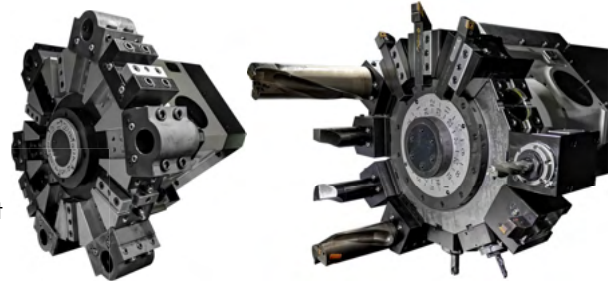

### Programmable Tailstock Body & Quill

Wide-spaced guideways and heavy-duty tailstock body design ensure machining rigidity, and built in spindle quill design ensures higher rigidity.

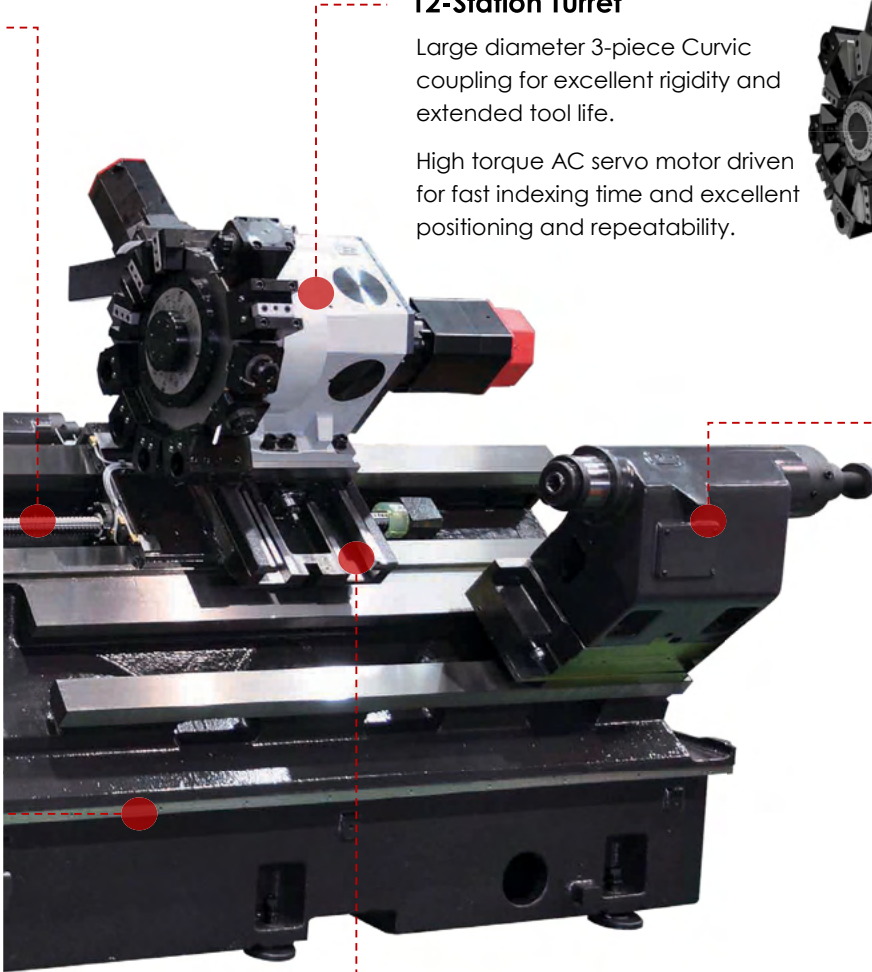

### Hexahedral Slide Ways (X-axis)

Wide boxways, machined from one-piece casting, promote heavy-duty machining.

Induction hardened and precision ground ways ensure accurate machining for extended periods of time.

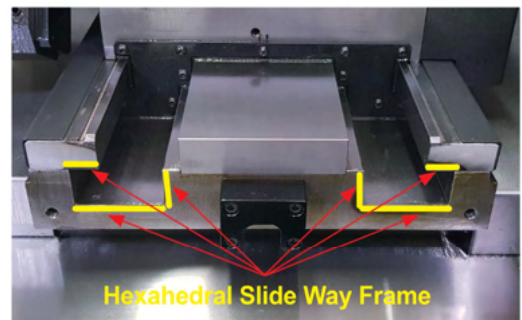

### Hand Scraping

Precise hand scraping on all the contact surface to the bed ensures long-lasting machining accuracy and minimal surface wears.



Hexahedral Slide Way Frame

**NL 150 | 200 | 250** 6", 8", 10" Chuck / A2-5, A2-6, A2-8 spindle nose

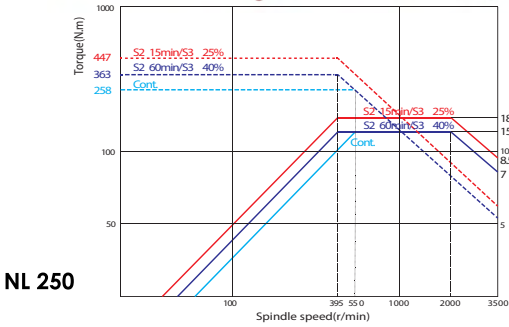

**NL 250**

**NL 150**

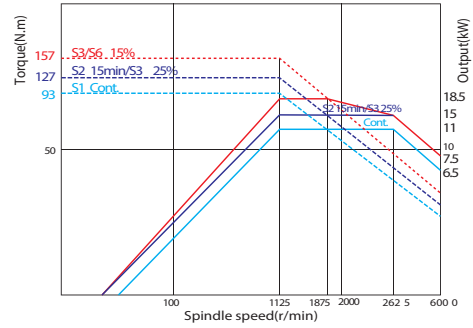

**NL 200**

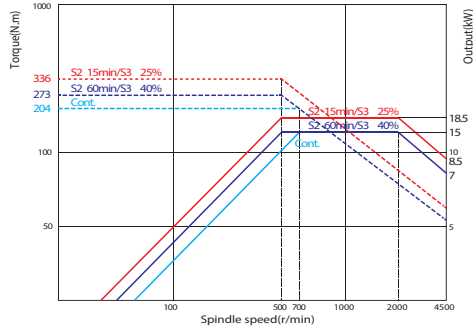

**Turret Head Interference** Unit: mm(inch)

**Work Range** Unit: mm(inch)

6

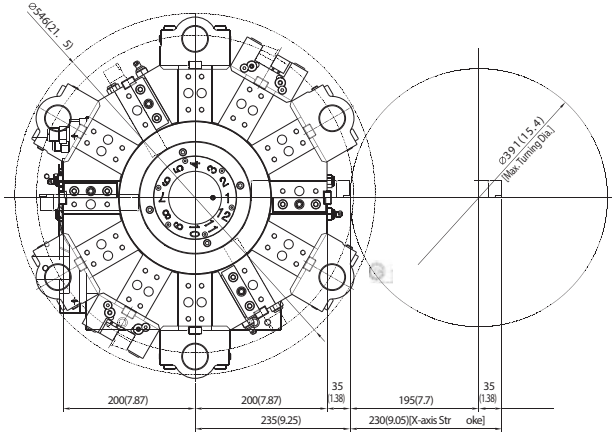

**NL 150**

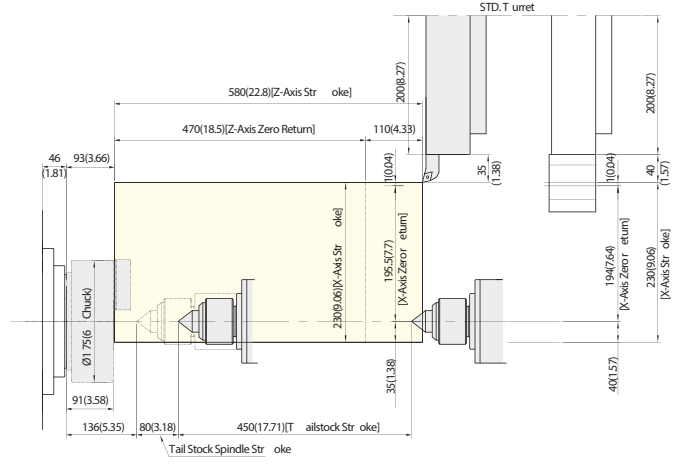

**NL 150**

**Machine Dimensions** Unit: mm(inch)

**NL 150 [NL 200 | 250]**

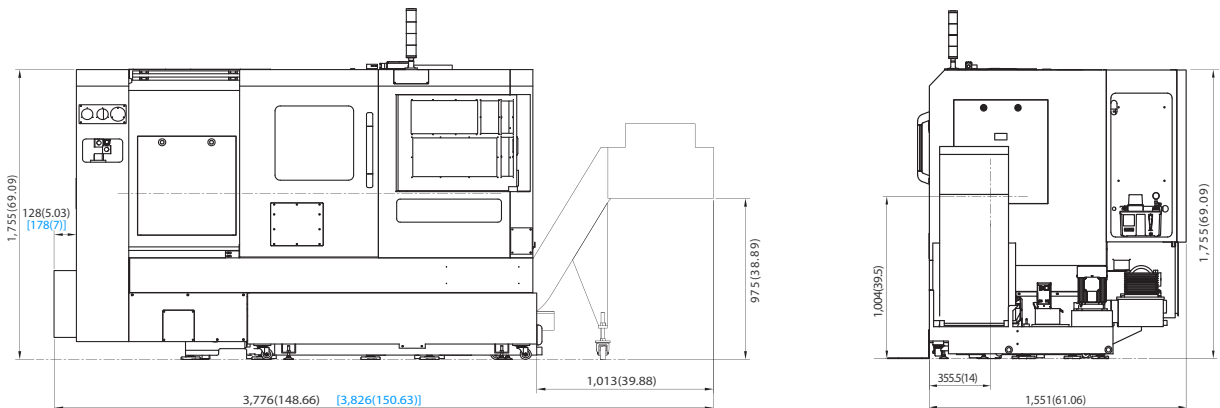

**Machine Dimensions**

DESCRIPTION		NL 150	NL 200	NL 250	
CAPACITY	Swing over the bed	mm(inch)	570(22.44)		
	Swing over the cross slide	mm(inch)	370(14.57)		
	Max. machining diameter	mm(inch)	391 (15.39)	391 (15.39)	391 (15.39)
	Max. machining length	mm(inch)	560(22.05)	560(22.05)	550(21.65)
	Chuck size	inch	6	8	10
	Bar working dia.	mm(inch)	51(2.01)	67(2.64)	81(3.19)
SPINDLE	Spindle speed	rpm	6,000	4,500	3,500
	Spindle motor	kW(Hp)	11/18.5(15/25)	15/18.5(20/25)	
	Spindle nose	ASA	A2-5	A2-6	A2-8
	Spindle torque	N.m(ft.lbs)	157(115.8)	336(247.8)	447(329.7)
	Spindle through hole dia.	mm(inch)	61(2.4)	76(2.99)	91(3.58)
TRAVEL	Rapid traverse (X/Z)	m/min(ipm)	24/30(945/1,181)		
	X/Z axis travel	mm(inch)	230/580(9.06/22.83)		
	Feed motor (X/Z)	kW(hp)	1.8/3(2.4/4)	1.8/3(2.4/4)	1.8/3(2.4/4)
TURRET	Number of tool stations	st.	12		
	OD tool size	mm(inch)	□25(□1 )		
	Max. boring bar size	mm(inch)	40(1.5)		50(2)
	Indexing time	sec	0.15		
	Milling tool holder type	-	-	-	-
	Max. rotary tool spindle speed	rpm	-	-	-
	Rotary tool motor power	kW(hp)	-	-	-
TAILSTOCK	Tailstock travel	mm(inch)	450(17.72)		
	Quill diameter	mm(inch)	80(3.15)		
	Quill travel	mm(inch)	80(3.15)		
	Taper of tailstock spindle	-	MT#4 Live center		
<b>BED TYPE</b>	-	45° Slant			
<b>ELECTRIC POWER SUPPLY</b>	kVA	31			
<b>REQUIRED FLOOR SPACE</b>	mm(inch)	3,140×1,560(124×62)			
<b>MACHINE WEIGHT</b>	kg(lbs)	3,800(8,378)	3,900(8,598)		
<b>CONTROLLER</b>	-	Fanuc Oi-TF			

- Figures in inches are converted from metric measurements.
- Design and specifications are subject to change without notice.

**Standard Accessories**

- Coolant unit [4.5bar (65PSI)]
- Manual tailstock
- Work light (LED lamp)
- Splash guard with side coolant tank
- Tool/Work box
- Hyd. Hollow chuck
- 2 set of soft jaws, 1 hard jaw
- Leveling blocks
- Chuck clamp foot switch
- Chuck clamp confirmation
- Manual/Part list
- Door interlock
- 3 step patrol light

**Optional Accessories**

- Chip conveyor
- Dual pressure chucking
- Auto door
- Oil skimmer
- Part catcher (Main/Sub)
- Coolant gun
- Tool presetter

**NL 1500 | 2000** 6", 8" Chuck / A2-5, A2-6 spindle nose



**NL 1500**

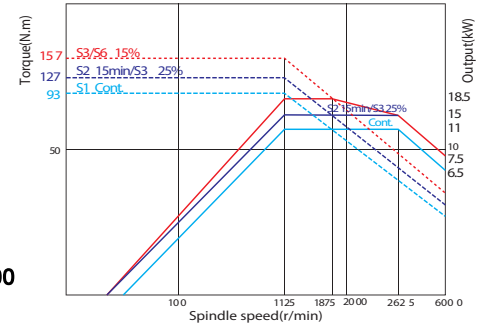

**NL 2000**

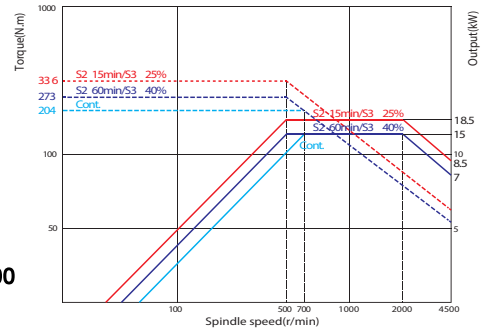

**Turret Head Interference** Unit: mm(inch)

**Work Range** Unit: mm(inch)

8

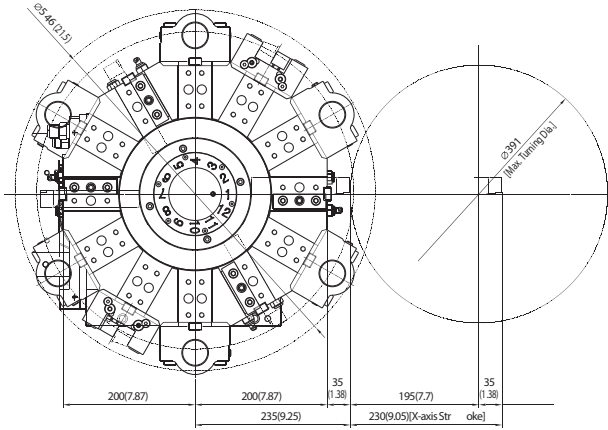

**NL 2000**

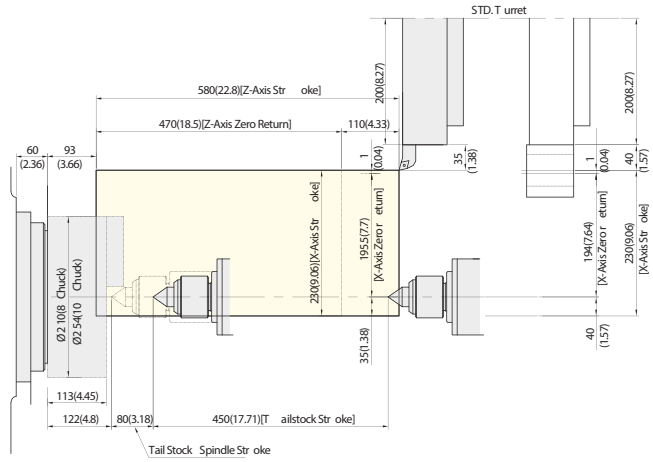

**NL 2000**

**Machine Dimensions** Unit: mm(inch)

**NL 1500 [NL 2000]**

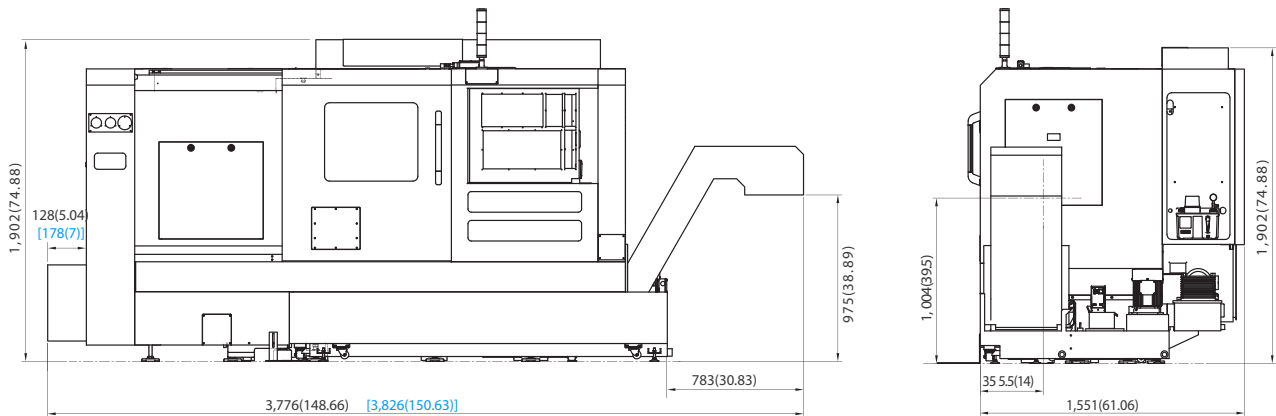



**Machine Dimensions**

DESCRIPTION			NL 1500	NL 1500M	NL 2000	NL 2000M
CAPACITY	Swing over the bed	mm(inch)	570(22.44)			
	Swing over the cross slide	mm(inch)	370(14.57)			
	Max. machining diameter	mm(inch)	391(15.39)	381(15.0)	391(15.39)	381(15.0)
	Max. machining length	mm(inch)	560(22.05)	540(21.26)	560(22.05)	540(21.26)
	Chuck size	inch	6		8	
	Bar working dia.	mm(inch)	51(2.01)		67(2.64)	
SPINDLE	Spindle speed	rpm	6,000		4,500	
	Spindle motor	kW(Hp)	11/18.5(15/25)		15/18.5(20/25)	
	Spindle nose	ASA	A2-5		A2-6	
	Spindle torque	N.m(ft.lbs)	157(115.8)		336(247.8)	
	Spindle through hole dia.	mm(inch)	61(2.4)		76(2.99)	
TRAVEL	Rapid traverse (X/Z)	m/min(ipm)	24/30(945/1,181)			
	X/Z axis travel	mm(inch)	230/580(9.06/22.83)			
	Feed motor (X/Z)	kW(hp)	1.8/3(2.4/4)	3/3(4/4)	1.8/3(2.4/4)	3/3(4/4)
TURRET	Number of tool stations	st.	12	12 (24)	12	12 (24)
	OD tool size	mm(inch)	□25(□1 )			
	Max. boring bar size	mm(inch)	40(1.5)			
	Indexing time	sec	0.15			
	Milling tool holder type	-	-	BMT55	-	BMT55
	Max. rotary tool spindle speed	rpm	-	5,000	-	5,000
	Rotary tool motor power	kW(hp)	-	3.7/5.5(5/7.4)	-	3.7/5.5(5/7.4)
TAILSTOCK	Tailstock travel	mm(inch)	450(17.72)			
	Quill diameter	mm(inch)	80(3.15)			
	Quill travel	mm(inch)	80(3.15)			
	Taper of tailstock spindle	-	MT#4 Live center			
BED TYPE	-	45° Slant				
ELECTRIC POWER SUPPLY	kVA	31				
REQUIRED FLOOR SPACE	mm(inch)	3,140×1,560(124×62)				
MACHINE WEIGHT	kg(lbs)	3,800(8,378)		3,900(8,598)		
CONTROLLER	-	Fanuc Oi-TF				

- Figures in inches are converted from metric measurements.
- Design and specifications are subject to change without notice.

**Standard Accessories**

- Coolant unit [10bar (140PSI)]
- Work light (LED lamp)
- Splash guard with side coolant tank
- Tool/Work box
- Hyd. Hollow chuck
- 2 set of soft jaws, 1 hard jaw
- Leveling blocks
- Chuck clamp foot switch
- Chuck clamp confirmation
- Manual/Part list
- Door interlock
- Tailstock in-out foot switch
- 3 step patrol light

**Optional Accessories**

- Chip conveyor
- Dual pressure chucking
- Auto door
- Oil skimmer
- Part catcher (Main/Sub)
- Coolant gun
- Tool presetter

**NL 2500 | NL 3000** 10", 12" Chuck / A2-8, A2-11 spindle nose



**NL 2500**

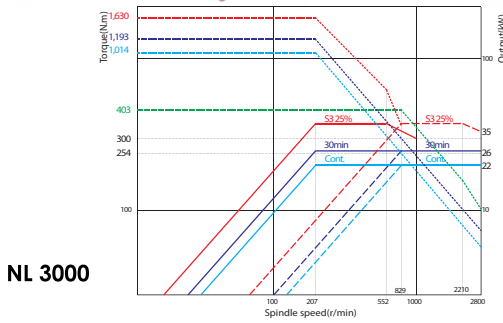
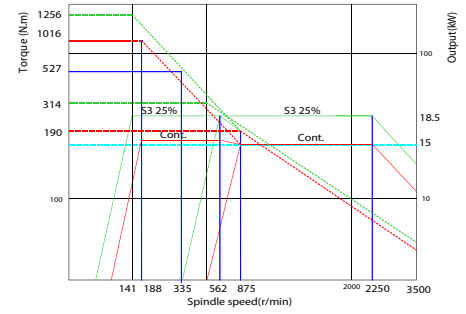

**NL 3000**

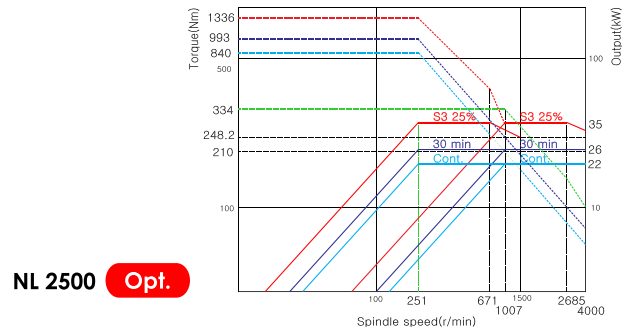

**NL 2500 Opt.**

**Turret Head Interference** Unit: mm(inch)

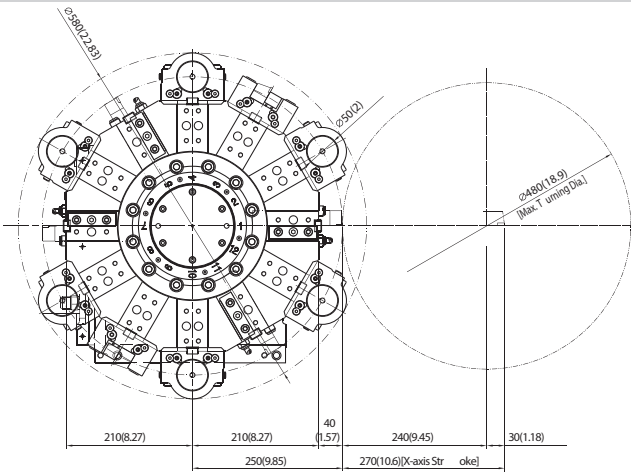

**NL 2500 | 3000**

**Work Range** Unit: mm(inch)

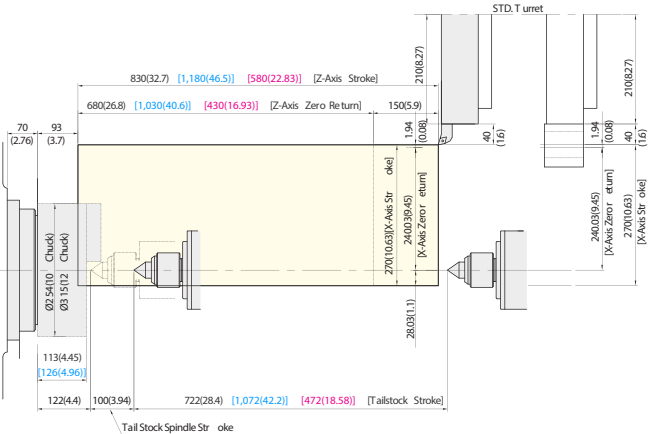

**NL 2500/750 | NL 3000B/750 [NL 3000B/1100] [NL 2500/500]**

**Machine Dimensions** Unit: mm(inch)

**NL 2500/750 | NL 3000B/750 [NL 3000B/1100] [NL 2500/500]**

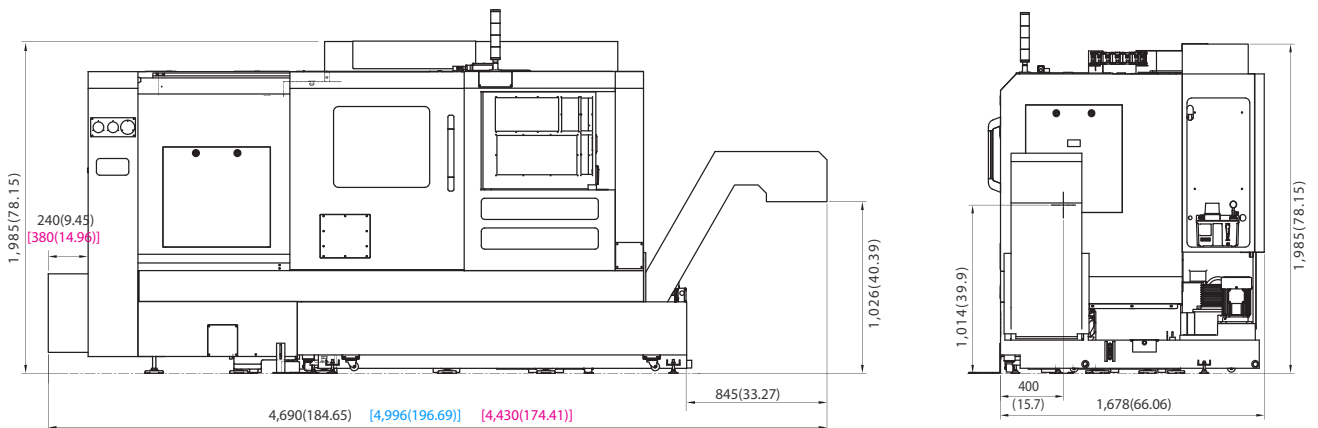

### Machine Dimensions

DESCRIPTION			NL 2500/750 [NL 2500/500]	NL 2500M/750	NL 3000B/750 [NL 3000B/1100]	NL 3000BM/750 [NL 3000BM/1100]
CAPACITY	Swing over the bed	mm(inch)	700(27.56)			
	Swing over the cross slide	mm(inch)	510(20.08)			
	Max. machining diameter	mm(inch)	480(18.9)	450(17.72)	480(18.9)	450(17.72)
	Max. machining length	mm(inch)	750(29.53) [530(20.87)]	700(27.56)	750(29.53) [1,100(43.31)]	700(27.56) [1,050(41.34)]
	Chuck size	inch	10		12	
	Bar working dia.	mm(inch)	81(3.19)		102(4.02)	
SPINDLE	Spindle speed	rpm	3,500 {4,000}		2,800	
	Spindle motor	kW(Hp)	15/18.5(20/25) {22/35(29.5/47)}		22/35(29.5/47)	
	Spindle nose	ASA	A2-8		A2-11	
	Spindle torque	N.m(ft.lbs)	1,256(926.4) {1,336(985.4)}		1,630(1,202.2)	
	Spindle through hole dia.	mm(inch)	91(3.58)		115(4.53)	
TRAVEL	Rapid traverse (X/Z)	m/min(ipm)	24/30(945/1,181)			
	X-axis travel	mm(inch)	270(10.63)			
	Z-axis travel	mm(inch)	830(32.68) [580(22.83)]	770(30.31)	830(32.68) [1,180(46.46)]	770(30.31) [1,120(44.09)]
	Feed motor (X/Z)	kW(hp)	4/4(5.4/5.4)			
TURRET	Number of tool stations	st.	12	12 (24)	12	12 (24)
	OD tool size	mm(inch)	□25(□1 )			
	Max. boring bar size	mm(inch)	50(2)			
	Indexing time	sec	0.2			
	Milling tool holder type	-	-	BMT65	-	BMT65
	Max. rotary tool spindle speed	rpm	-	5,000	-	5,000
	Rotary tool motor power	kW(hp)	-	3.7/5.5/7.5(5/7.4/10)	-	3.7/5.5/7.5(5/7.4/10)
TAILSTOCK	Tailstock travel	mm(inch)	720(28.35) [440(17.32)]		720(28.35) [1,060(41.73)]	
	Quill diameter	mm(inch)	110(4.33)			
	Quill travel	mm(inch)	100(3.94)			
	Taper of tailstock spindle	-	MT#4(Built-in)			
BED TYPE	-	45° Slant				
ELECTRIC POWER SUPPLY	kVA	35 {40}			40	
REQUIRED FLOOR SPACE	mm(inch)	3,708×1,727(146×68) [3,208×1,778(126.3×70)]			3,708×1,727(146×68) [4,013×1,727(158×68)]	
MACHINE WEIGHT	kg(lbs)	5,700(12,566) [4,700(10,361)]			5,700(12,566) [6,900(15,211)]	
CONTROLLER	-	Fanuc Oi-TF				

- Figures in inches are converted from metric measurements.
- Design and specifications are subject to change without notice.

{ } : Option

### Standard Accessories

- Coolant unit [10bar (140PSI)]
- Work light (LED lamp)
- Splash guard with side coolant tank
- Tool/Work box
- Hyd. Hollow chuck
- 2 set of soft jaws, 1 hard jaw
- Leveling blocks
- Chuck clamp foot switch
- Chuck clamp confirmation
- Manual/Part list
- Door interlock
- Tailstock in-out foot switch
- 3 step patrol light

### Optional Accessories

- Chip conveyor
- Dual pressure chucking
- Auto door
- Oil skimmer
- Part catcher (Main/Sub) [NL2500(M) only]
- Coolant gun
- Tool presetter

**NL 4000 | NL 5000** 18", 21" Chuck / A2-11, A2-15 spindle nose



**NL 4000**

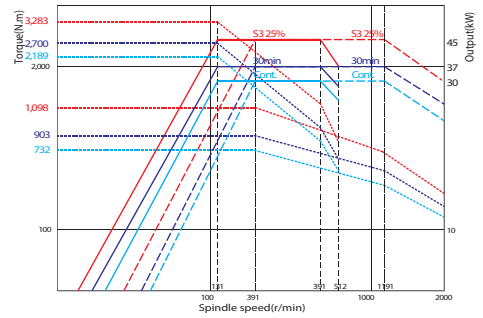

**NL 5000**

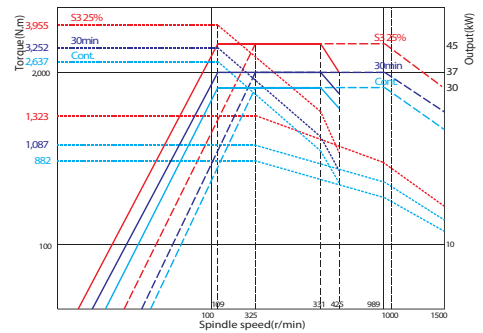

**Turret Head Interference**

Unit: mm(inch)

**Work Range**

Unit: mm(inch)

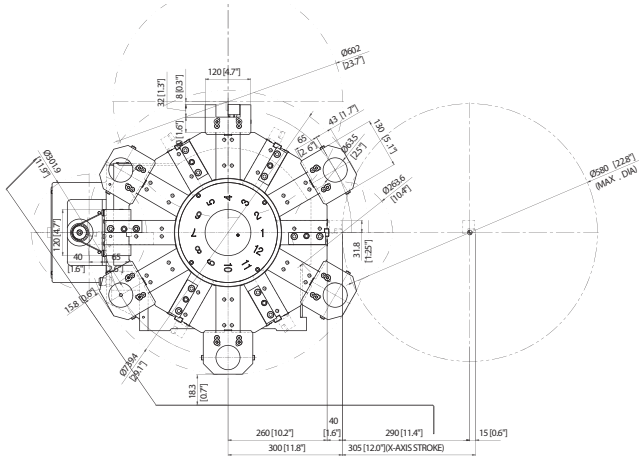

**NL 5000**

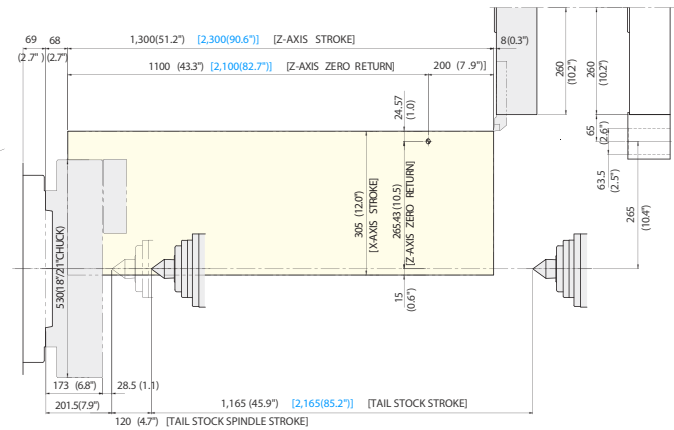

**NL 5000/1200 [NL 5000/2200]**

**Machine Dimensions**

Unit: mm(inch)

**NL 4000/1200 | NL 5000/1200 [NL 5000/2200]**

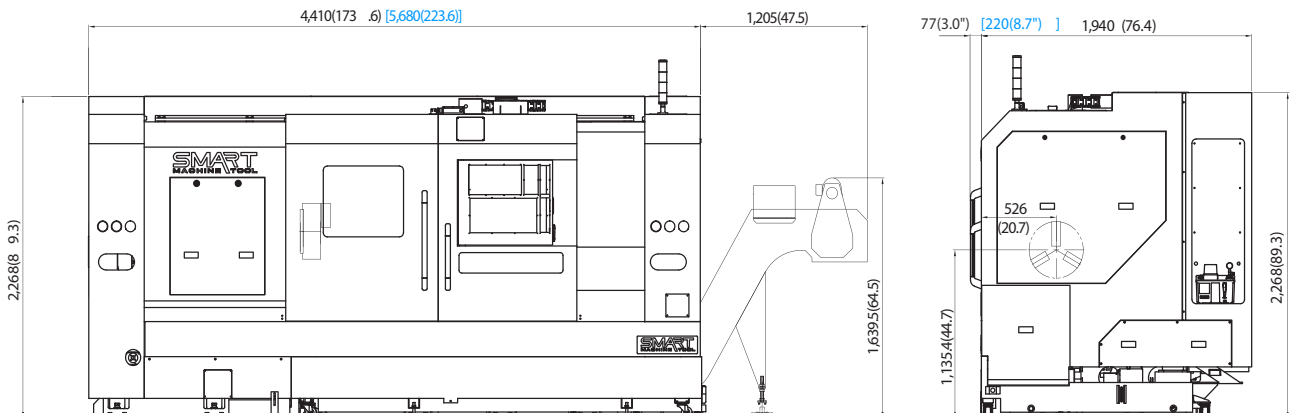

## Machine Dimensions

DESCRIPTION		NL 4000/1200	NL 4000M/1200	NL 5000/1200	NL 5000M/1200	NL 5000/2200	NL 5000M/2200	
CAPACITY	Swing over the bed	790 (31.1)						
	Swing over the cross slide	600 (23.62)						
	Max. machining diameter	580 (22.83)	560 (22.05)	580 (22.83)	560 (22.05)	580 (22.83)	560 (22.05)	
	Max. machining length	1,213 (47.76)	1,145 (45.08)	1,155(45.47)	1,119(44.06)	2,155(84.84)	2,119(83.43)	
	Chuck size	18			21			
	Bar working dia.	116.5 (4.59)			165.5 (6.52)			
SPINDLE	Spindle speed	2,000			1,500			
	Spindle motor	30/45 (40/60)						
	Spindle nose	A2 - 11			A2 - 15			
	Spindle torque	3,283 (2,421)			3,955 (2,917)			
	Spindle through hole dia.	132 (5.2)			181(7.125)			
TRAVEL	Rapid traverse (X/Z)	16/20 (630/787)						
	Travel (X/Z)	320/1,300 (12.6/51.2)		320/1,300 (12.6/51.2)		320/2,300 (12.6/90.6)		
	Feed motor (X/Z)	4/7 (5.4/9.4)			7/6 (9.4/8)			
TURRET	Number of tool positions	12						
	OD tool size	□32 (□1.25)						
	Max. boring bar size	60 (2.5)						
	Indexing time	0.25/Step						
	Milling tool holder type	-	BMT75	-	BMT75	-	BMT75	
	Max. rotary tool spindle speed	-	4,000	-	4,000	-	4,000	
	Rotary tool motor power	-	7.5/11/15 (10/14.8/20.1)	-	7.5/11/15 (10/14.8/20.1)	-	7.5/11/15 (10/14.8/20.1)	
TAILSTOCK	Tailstock travel	1,165 (45.87)				2,165 (85.24)		
	Tailstock spindle diameter	140 (5.51)						
	Taper of tailstock spindle	MT#5 (Built-in)						
	Tailstock spindle travel	120 (4.72)						
BED TYPE	45° Slant							
ELECTRIC POWER SUPPLY	55							
REQUIRED FLOOR SPACE	4,450(175.2)×2,017(79.4)				5,720(225.2) x 2,205(86.8)			
MACHINE WEIGHT	10,700(23,589)	10,800(23,810)	10,800(23,810)	10,900(24,030)	13,700(30,203)	13,800(30,424)		
CONTROLLER	Fanuc Oi-TF							

- Figures in inches are converted from metric measurements.
- Design and specifications are subject to change without notice.

### Standard Accessories

- Coolant unit [10bar (140PSI)]
- Work light (LED lamp)
- Splash guard with side coolant tank
- Tool/Work box
- Hyd. Hollow chuck
- 2 set of soft jaws, 1 hard jaw
- Leveling blocks
- Chuck clamp foot switch
- Chuck clamp confirmation
- Manual/Part list
- Door interlock
- Tailstock in-out foot switch
- 3 step patrol light

### Optional Accessories

- Chip conveyor
- Dual pressure chucking
- Auto door
- Coolant gun
- Tool presetter
- Oil skimmer
- Steady rest prep

**NL 6000** 24" Chuck / A1-15, A1-20 spindle nose



**NL 6000**

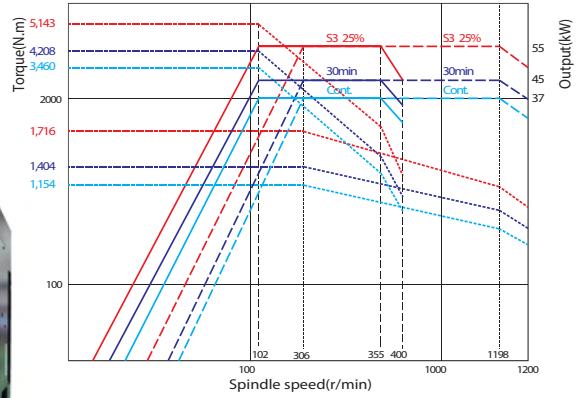

**Turret Head Interference**

Unit: mm(inch)

**Work Range**

Unit: mm(inch)

14

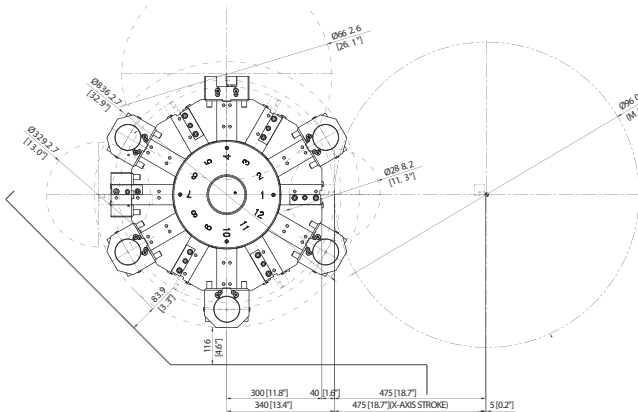

**NL 6000**

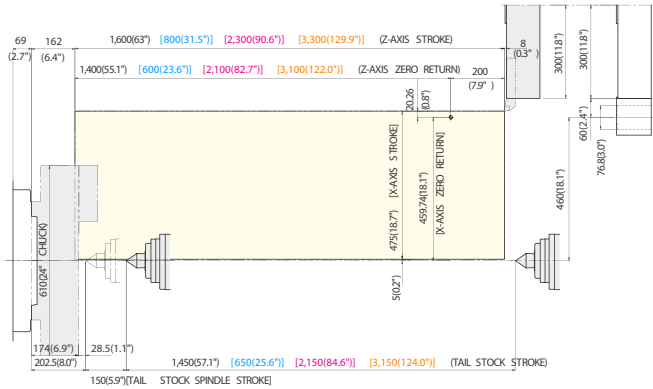

**NL 6000/1500 [NL 6000/750] [NL 6000/2200] [NL 6000/3200]**

**Machine Dimensions**

Unit: mm(inch)

**NL 6000/1500 [NL 6000/750] [NL 6000/2200] [NL 6000/3200]**

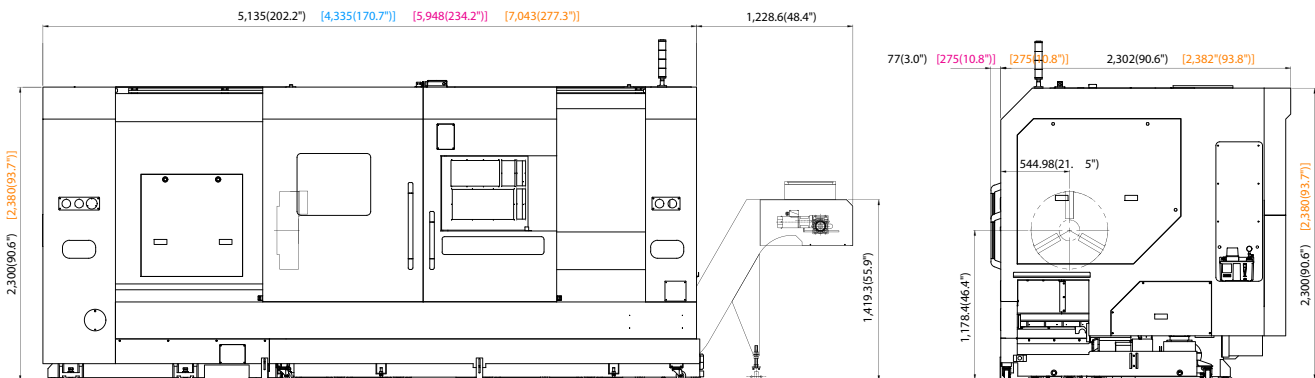

**Machine Dimensions**

DESCRIPTION			NL 6000/750	NL 6000M/750	NL 6000/1500	NL 6000M/1500
<b>CAPACITY</b>	Swing over the bed	mm(inch)	1,030 (40.55)			
	Swing over the cross slide	mm(inch)	850 (33.46)			
	Max. machining diameter	mm(inch)	960 (37.80)	900 (35.43)	960 (37.80)	900 (35.43)
	Max. machining length	mm(inch)	750 (29.53)	700 (27.56)	1,550 (61.02)	1,500 (59.06)
	Chuck size	inch	24			
	Bar working dia.	mm(inch)	165.5 (6.52)			
<b>SPINDLE</b>	Spindle speed	rpm	1,200			
	Spindle motor	kW(Hp)	37/55 (50/73)			
	Spindle nose	ASA	A1 - 15			
	Spindle torque	N.m(ff.lbs)	5,143 (3,793.3)			
	Spindle through hole dia.	mm(inch)	181 (7.125)			
<b>TRAVEL</b>	Rapid traverse (X/Z)	m/min(ipm)	16/20 (630/787)			
	Travel (X/Z)	mm(inch)	475/800 (18.7/31.5)		475/1,600 (18.7/63)	
	Feed motor (X/Z)	kW(hp)	7/6 (9.4/8)			
<b>TURRET</b>	Number of tool positions	st.	12			
	OD tool size	mm(inch)	□32 (□1.25)			
	Max. boring bar size	mm(inch)	80 (3)			
	Indexing time	sec	0.25/Step	0.35/Step	0.25/Step	0.35/Step
	Milling tool holder type	-	-	BMT85	-	BMT85
	Max. rotary tool spindle speed	rpm	-	3,000	-	3,000
	Rotary tool motor power	kW(hp)	-	7.5/11/15 (10/14.8/20.1)	-	7.5/11/15 (10/14.8/20.1)
<b>TAILSTOCK</b>	Tailstock travel	mm(inch)	Option		1,450 (57.09)	
	Tailstock spindle diameter	mm(inch)	Option		180 (7.09)	
	Taper of tailstock spindle	-	Option		MT#6 (Built-in)	
	Tailstock spindle travel	mm(inch)	Option		150 (5.91)	
<b>BED TYPE</b>	-	45° Slant				
<b>ELECTRIC POWER SUPPLY</b>	kVA	65				
<b>REQUIRED FLOOR SPACE</b>	mm(inch)	4,390(172.8)x2,379(93.7)			5,191(204.4)x2,379(93.7)	
<b>MACHINE WEIGHT</b>	kg(lbs)	11,500(25,353)	12,000(26,455)	15,300(33,371)	15,800(34,833)	
<b>CONTROLLER</b>	-	Fanuc Oi-TF				

- Figures in inches are converted from metric measurements.
- Design and specifications are subject to change without notice.

**Standard Accessories**

- Coolant unit [10bar (140PSI)]
- Work light (LED lamp)
- Splash guard with side coolant tank
- Tool/Work box
- Hyd. Hollow chuck
- 2 set of soft jaws, 1 hard jaw
- Leveling blocks
- Chuck clamp foot switch
- Chuck clamp confirmation
- Manual/Part list
- Door interlock
- Tailstock in-out foot switch
- 3 step patrol light

**Optional Accessories**

- Chip conveyor
- Dual pressure chucking
- Auto door
- Coolant gun
- Tool presetter
- Oil skimmer
- Steady rest prep

## Machine Dimensions

DESCRIPTION			NL 6000/2200	NL 6000M/2200	NL 6000/3200	NL 6000M/3200
CAPACITY	Swing over the bed	mm(inch)	1,030 (40.55)			
	Swing over the cross slide	mm(inch)	850 (33.46)			
	Max. machining diameter	mm(inch)	960 (37.80)	900 (35.43)	960 (37.80)	900 (35.43)
	Max. machining length	mm(inch)	2,250 (88.58)	2,200 (86.61)	3,250 (127.95)	3,200 (125.98)
	Chuck size	inch	24			
	Bar working dia.	mm(inch)	165.5 (6.52)			
SPINDLE	Spindle speed	rpm	1,200			
	Spindle motor	kW(Hp)	37/55 (50/73)			
	Spindle nose	ASA	A1 - 15			
	Spindle torque	N.m(ft.lbs)	5,143 (3,793.3)			
	Spindle through hole dia.	mm(inch)	181 (7.125)			
TRAVEL	Rapid traverse (X/Z)	m/min(ipm)	16/16 (630/630)		16/10 (630/394)	
	Travel (X/Z)	mm(inch)	475/2,300 (18.7/90.55)		475/3,300 (18.7/129.92)	
	Feed motor (X/Z)	kW(hp)	7/6 (9.4/8)			
TURRET	Number of tool positions	st.	12			
	OD tool size	mm(inch)	□32 (□1.25)			
	Max. boring bar size	mm(inch)	80 (3)			
	Indexing time	sec	0.25/Step	0.35/Step	0.25/Step	0.35/Step
	Milling tool holder type	-	-	BMT85	-	BMT85
	Max. rotary tool spindle speed	rpm	-	3,000	-	3,000
	Rotary tool motor power	kW(hp)	-	7.5/11/15 (10/14.8/20.1)	-	7.5/11/15 (10/14.8/20.1)
TAILSTOCK	Tailstock travel	mm(inch)	2,150(84.65)		3,150(124.02)	
	Tailstock spindle diameter	mm(inch)	180 (7.09)			
	Taper of tailstock spindle	-	MT#6 (Built-in)			
	Tailstock spindle travel	mm(inch)	150(5.91)			
BED TYPE	-	45° Slant				
ELECTRIC POWER SUPPLY	kVA	65				
REQUIRED FLOOR SPACE	mm(inch)	6,004(236.4)x2,389(94.1)			7,100(279.5)x2,469(97.2)	
MACHINE WEIGHT	kg(lbs)	17,300(38,140)	17,800(39,242)	19,800(43,652)	20,300(44,754)	
CONTROLLER	-	Fanuc Oi-TF				

- Figures in inches are converted from metric measurements.
- Design and specifications are subject to change without notice.

### Standard Accessories

- Coolant unit [10bar (140PSI)]
- Work light (LED lamp)
- Splash guard with side coolant tank
- Tool/Work box
- Hyd. Hollow chuck
- 2 set of soft jaws, 1 hard jaw
- Leveling blocks
- Chuck clamp foot switch
- Chuck clamp confirmation
- Manual/Part list
- Door interlock
- Tailstock in-out foot switch
- 3 step patrol light

### Optional Accessories

- Chip conveyor
- Dual pressure chucking
- Auto door
- Coolant gun
- Tool presetter
- Oil skimmer
- Steady rest prep



**Machine Dimensions**

DESCRIPTION		NL 6000C/1500	NL 6000C/2200	NL 6000C/3200	
CAPACITY	Swing over the bed	mm(inch)	1,030 (40.55)		
	Swing over the cross slide	mm(inch)	850 (33.46)		
	Max. machining diameter	mm(inch)	960 (37.80)	960 (37.80)	960 (37.80)
	Max. machining length	mm(inch)	1,550 (61.02)	2,250 (88.58)	3,250 (127.95)
	Chuck size	inch	user scope		
	Bar working dia.	mm(inch)	-		
SPINDLE	Spindle speed	rpm	1,000		
	Spindle motor	kW(Hp)	37/55 (50/73)		
	Spindle nose	ASA	A1 - 20		
	Spindle torque	N.m(ft.lbs)	5,143 (3,793.3)		
	Spindle through hole dia.	mm(inch)	275(10.83)		
TRAVEL	Rapid traverse (X/Z)	m/min(ipm)	16/20 (630/787)	16/16 (630/630)	16/10 (630/394)
	Travel (X/Z)	mm(inch)	475/1,600 (18.7/63)	475/2,300 (18.7/90.55)	475/3,300 (18.7/129.92)
	Feed motor (X/Z)	kW(hp)	7/6 (9.4/8)		
TURRET	Number of tool positions	st.	12		
	OD tool size	mm(inch)	□32 (□1.25)		
	Max. boring bar size	mm(inch)	80 (3)		
	Indexing time	sec	0.25/Step		
	Milling tool holder type	-	-	-	-
	Max. rotary tool spindle speed	rpm	-	-	-
	Rotary tool motor power	kW(hp)	-	-	-
TAILSTOCK	Tailstock travel	mm(inch)	1,450(57.09)	2,150(84.65)	3,150(124.02)
	Tailstock spindle diameter	mm(inch)	180 (7.09)		
	Taper of tailstock spindle	-	MT#6 (Built-in)		
	Tailstock spindle travel	mm(inch)	150(5.91)		
BED TYPE	-	45° Slant			
ELECTRIC POWER SUPPLY	kVA	65			
REQUIRED FLOOR SPACE	mm(inch)	5,191x2,379 (204.4x93.7)	6,004x2,389 (236.4x94.1)	7,100x2,469 (279.5x97.2)	
MACHINE WEIGHT	kg(lbs)	15,300(33,371)	17,300(38,140)	19,800(43,652)	
CONTROLLER	-	Fanuc Oi-TF			

- Figures in inches are converted from metric measurements.
- Design and specifications are subject to change without notice.

**Standard Accessories**

- Coolant unit [10bar (140PSI)]
- Work light (LED lamp)
- Splash guard with side coolant tank
- Tool/Work box
- Hyd. Hollow chuck
- 2 set of soft jaws, 1 hard jaw
- Leveling blocks
- Chuck clamp foot switch
- Chuck clamp confirmation
- Manual/Part list
- Door interlock
- Tailstock in-out foot switch
- 3 step patrol light

**Optional Accessories**

- Chip conveyor
- Dual pressure chucking
- Auto door
- Coolant gun
- Tool presetter
- Oil skimmer
- Steady rest prep

## SMART Y-Axis Turning Centers

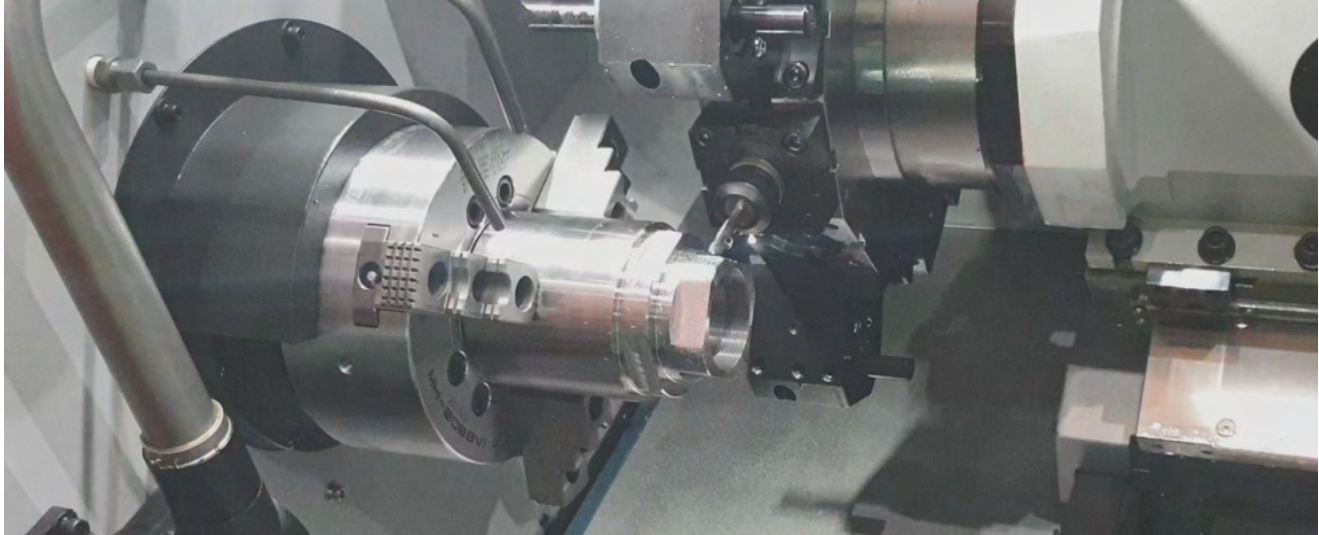

### 12-Station (24 Position) BMT Turret

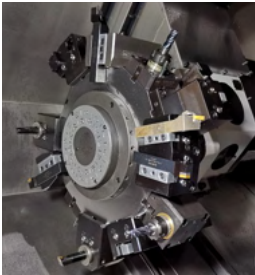

BMT turret is equipped with 2 separated motors for indexing and milling, ensuring high machining performance, reliability and reducing processing time of workpiece.

### Sub Spindle

Equipped with built-in motor and oil cooling unit to minimize thermal displacement and to ensure maximum machining accuracy even during a long period of machining.

### Synchronized C1 and C2 Axis Indexing

Provides maximum machining flexibility for varieties of workpiece configuration. From simple machining to multi-axis simultaneous machining, all operations can be completed in one set-up.

### Rigid 30 Degree Slant Bed

One-piece casting 30 degree slant torque tube design bed which provides maximum vibration dampening and improve machining stability during heavy duty cutting.

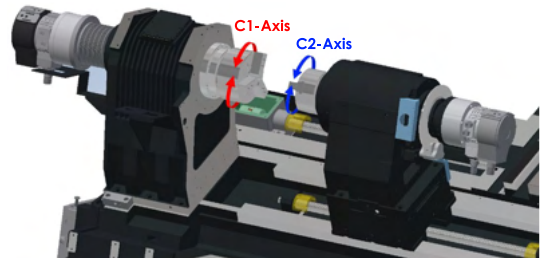
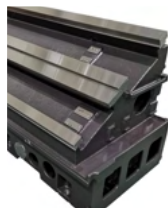

## Y-axis Machining Capability

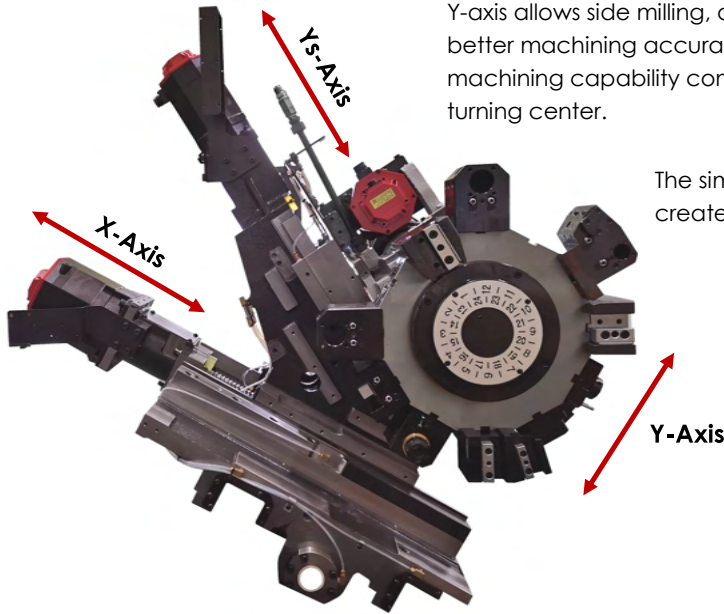

Y-axis allows side milling, off-center drilling and grooving. This result in better machining accuracy and also enable more complex shape machining capability compared to conventional 2 and 3 axis turning center.

The simultaneous operation of the X-axis and the Ys-axis creates the Y-axis movement.

### Y-Axis Travel

NL 2000: 110 mm (4.33 inch)

NL 2500: 110 mm (4.33 inch)

### Y-Axis Rapid Traverse

10 m/min (394 ipm)

■ Side milling

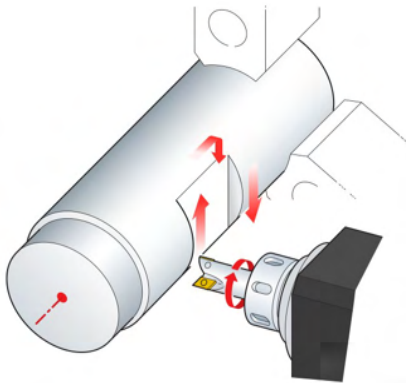

■ Off-center grooving

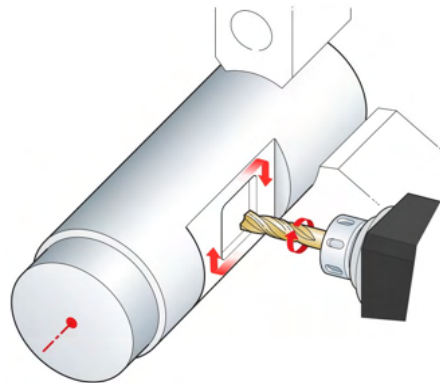

■ Off-center drilling

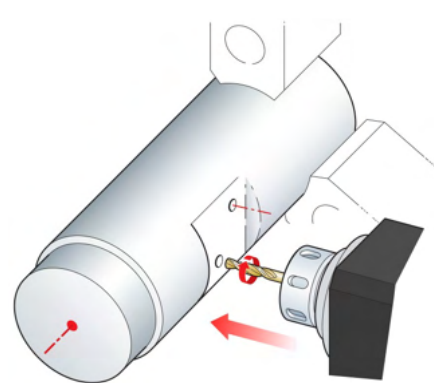

### Y-axis control compared to Polar coordinate interpolation

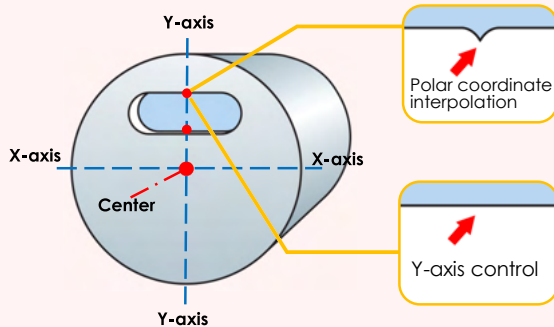

Polar coordinate interpolation control during grooving and contouring, the X-axis reverses at cross point between the center line and the profile to be machined which cause change in cutting condition and affect profile accuracy. Machining with Y-axis control can avoid such issue and also provide better profile accuracy.

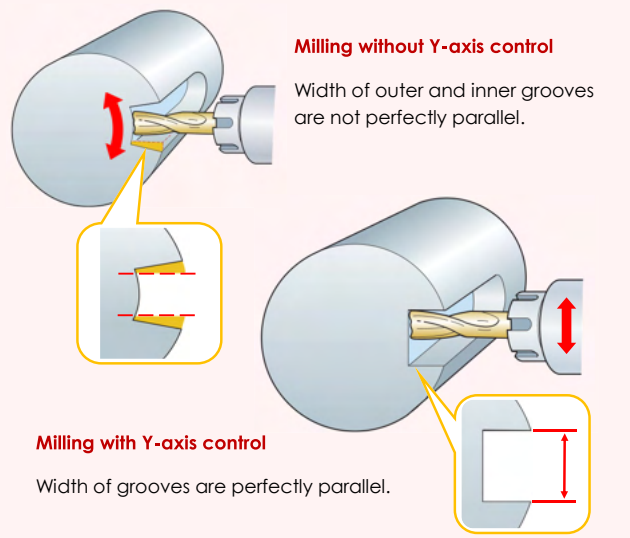

#### Milling without Y-axis control

Width of outer and inner grooves are not perfectly parallel.

#### Milling with Y-axis control

Width of grooves are perfectly parallel.

**NL 2000SY | NL 2500SY** 6-10" Chuck / A2-5, A2-6, A2-8 spindle nose



**NL 2000ASY**

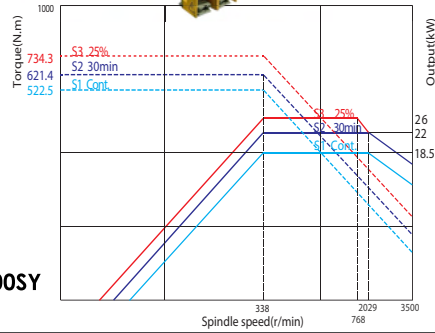
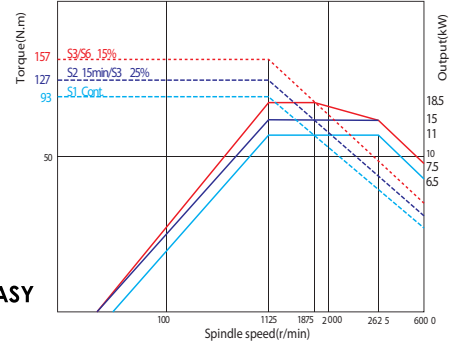

**NL 2500SY**

**NL 2000BSY**

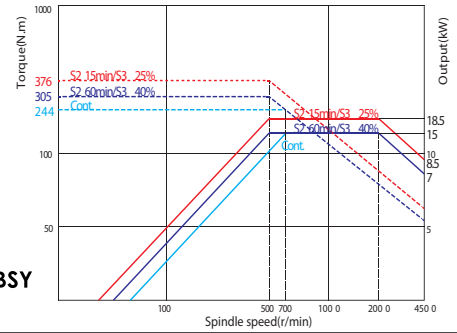

**Turret Head Interference** Unit: mm(inch)

**Work Range** Unit: mm(inch)

20

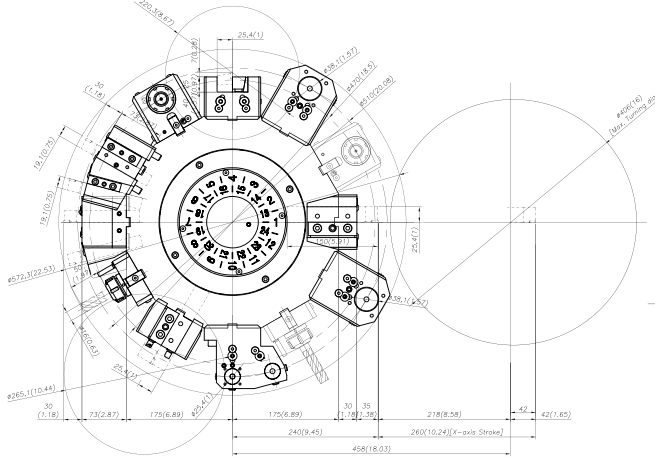

**NL 2000SY**

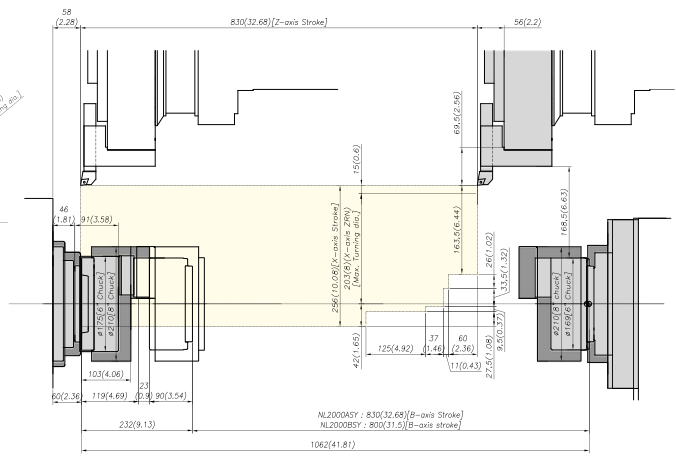

**NL 2000SY**

**Machine Dimensions** Unit: mm(inch)

**NL 2000SY [NL 2500SY]**

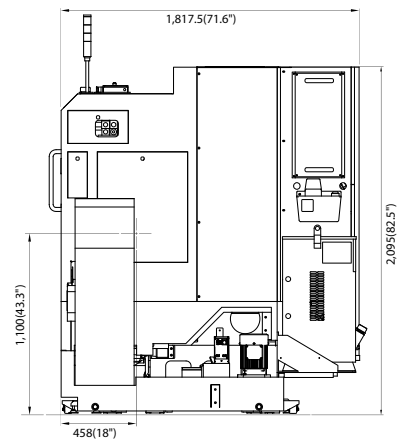
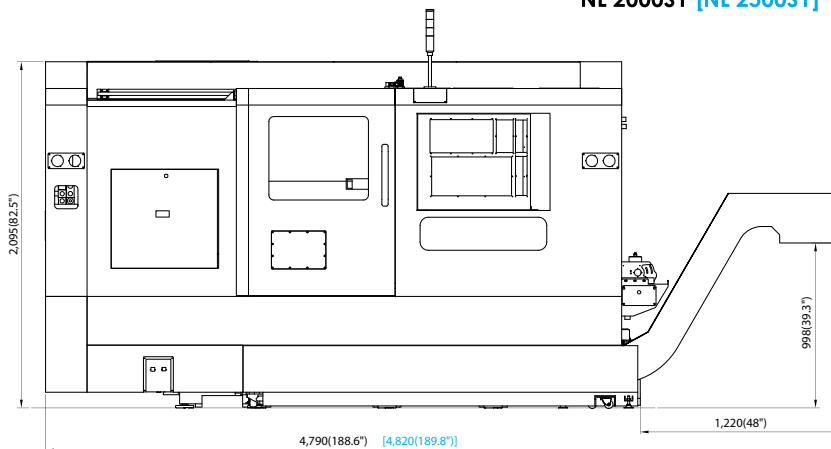

**Machine Dimensions**

DESCRIPTION		NL 2000ASY	NL 2000BSY	NL 2500SY	
CAPACITY	Swing over the bed	mm(inch)	685 (26.97)		
	Swing over the cross slide	mm(inch)	575 (22.63)		
	Max. machining diameter	mm(inch)	406 (15.98)		
	Max. machining length	mm(inch)	750 (29.5)	740 (29.13)	700 (27.56)
MAIN SPINDLE	Chuck size	inch	6	8	10
	Bar working dia.	mm(inch)	51 (2)	67 (2.64)	81 (3.19)
	Spindle speed	rpm	6,000	4,500	3,500
	Spindle motor	kW(Hp)	11/18.5 (15/25)	15/18.5 (20/25)	18.5/26 (25/35)
	Spindle torque	N.m(ft.lbs)	157 (115.8)	376 (277.3)	734.3 (541.6)
	Spindle nose	ASA	A2-5	A2-6	A2-8
	Spindle through hole dia.	mm(inch)	61 (2.4)	76 (2.99)	91 (3.58)
TRAVEL	Rapid traverse	X/Z	m/min(ipm)		30/30 (1,181/1,181)
		Y/B	m/min(ipm)		10/30 (394/1,181)
	Travel	X/Z	mm(inch)		256/830 (10.08/32.68)
		Y/B	mm(inch)		110/830 (4.33/32.68)
	Feed motor	X/Z	kW(hp)		3/3 (4/4)
		Y/B	kW(hp)		1.8/3 (2.4/4)
TURRET	Number of tool stations	st.	12 (24 positions)		
	OD tool size	mm(inch)	□25(1)		
	Max. boring bar size	mm(inch)	∅40(1.5)		∅50(2.0)
	Indexing time	sec	0.15		
	Milling tool holder type	-	BMT55		BMT65
	Max. rotary tool spindle speed	rpm	5,000		
	Rotary tool motor power	kW(hp)	5.5 (7.5)		7.5 (10)
SUB SPINDLE	Chuck size	inch	6	6 [8]	
	Bar working dia.	mm(inch)	51 (2)	51 (2)	
	Spindle speed	rpm	6,000	6,000 [5,000]	
	Spindle motor	kW(Hp)	15 (20)		
	Spindle torque	N.m(ft.lbs)	135 (99.6)		
	Spindle nose	ASA	A2-5	A2-5 [A2-6]	
	Spindle through hole dia.	mm(inch)	62 (2.44)		
BED TYPE		-	30° Slant		
ELECTRIC POWER SUPPLY		kVA	40	45	57
REQUIRED FLOOR SPACE		mm(inch)	3,570 x 1,818 (140.55 x 71.57)		3,700 x 1,818 (145.67 x 71.57)
MACHINE WEIGHT		kg(lbs)	5,700 (12,566)	5,800 (12,787)	6,100 (13,448)
CONTROLLER		-	Fanuc 0i-TF		

- Figures in inches are converted from metric measurements.
- Design and specifications are subject to change without notice.

[ ] : Option

**Standard Accessories**

- Coolant unit [10bar (140PSI)]
- Work light (LED lamp)
- Splash guard with side coolant tank
- Tool/Work box
- Hyd. Hollow chuck
- 2 set of soft jaws, 1 hard jaw
- Leveling blocks
- Chuck clamp foot switch
- Chuck clamp confirmation
- Manual/Part list
- Door interlock
- 3 step patrol light

**Optional Accessories**

- Chip conveyor
- Dual pressure chucking
- Auto door
- Oil skimmer
- Part catcher (Main/Sub)
- Part conveyor
- Coolant gun
- Tool presetter

Turning Performance

Heavy-duty cutting <O.D.>

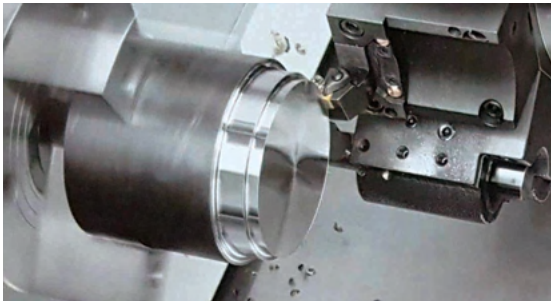

Machine Model	NL 2500
Material <JIS>	S45C
Spindle speed	367 min <sup>-1</sup>
Cutting depth	8mm (0.312 inch)
Cutting speed	152m/min (500 fpm)
Feedrate	0.5mm/rev (0.02 ipr)

Insert Drill

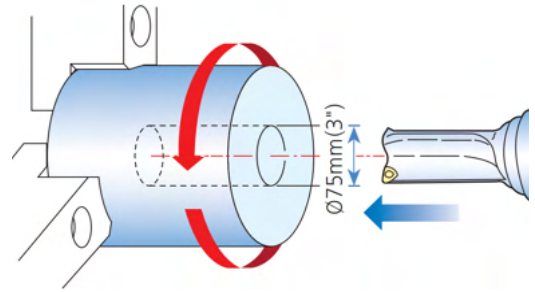

Machine Model	NL 2500
Material <JIS>	S45C
Spindle speed	417 min <sup>-1</sup>
Drill diameter	75mm (3 inch)
Feedrate	0.15mm/rev (0.006 ipr)

Milling capacity (material <JIS>:S45C)

End mill <Ø20mm(0.8") High-speed steel>

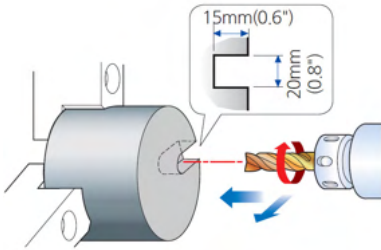

Machine Model	NL 2500
Material <JIS>	S45C
Tool spindle speed	320 min <sup>-1</sup>
Cutting depth	15mm(0.6 inch)
Cutting speed	20m/min (65.6 fpm)
Feedrate	65m/min (2.5 ipm)

Drill <Ø20mm(0.8") High-speed steel>

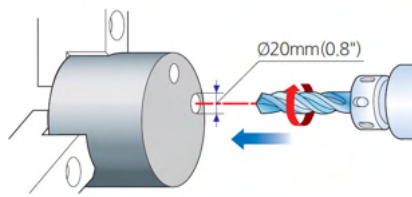

Machine Model	NL 2500
Material <JIS>	S45C
Tool spindle speed	391 min <sup>-1</sup>
Cutting speed	25m/min (82 fpm)
Feedrate	105m/min (4.1 ipm)

Tap <M18xP2.5>

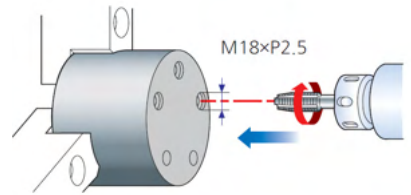

Machine Model	NL 2500
Material <JIS>	S45C
Tool spindle speed	160 min <sup>-1</sup>
Cutting speed	10m/min (32.8 fpm)
Feedrate	400m/min (15.7 ipm)

Rotary Tool Spindle Output Diagram

BMT 65

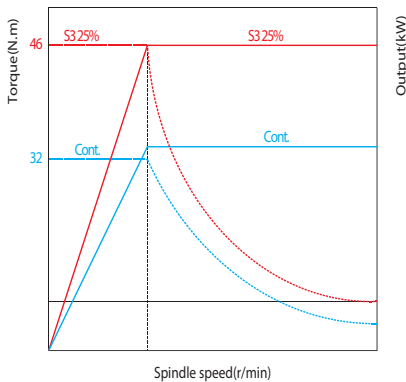

NL 2500/3000

BMT 75

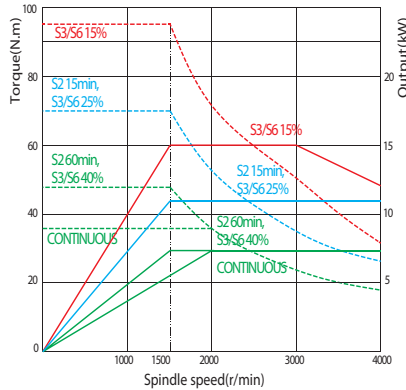

NL 4000/5000

BMT 85

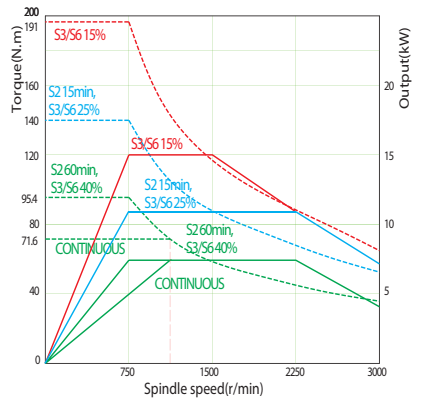

NL 6000

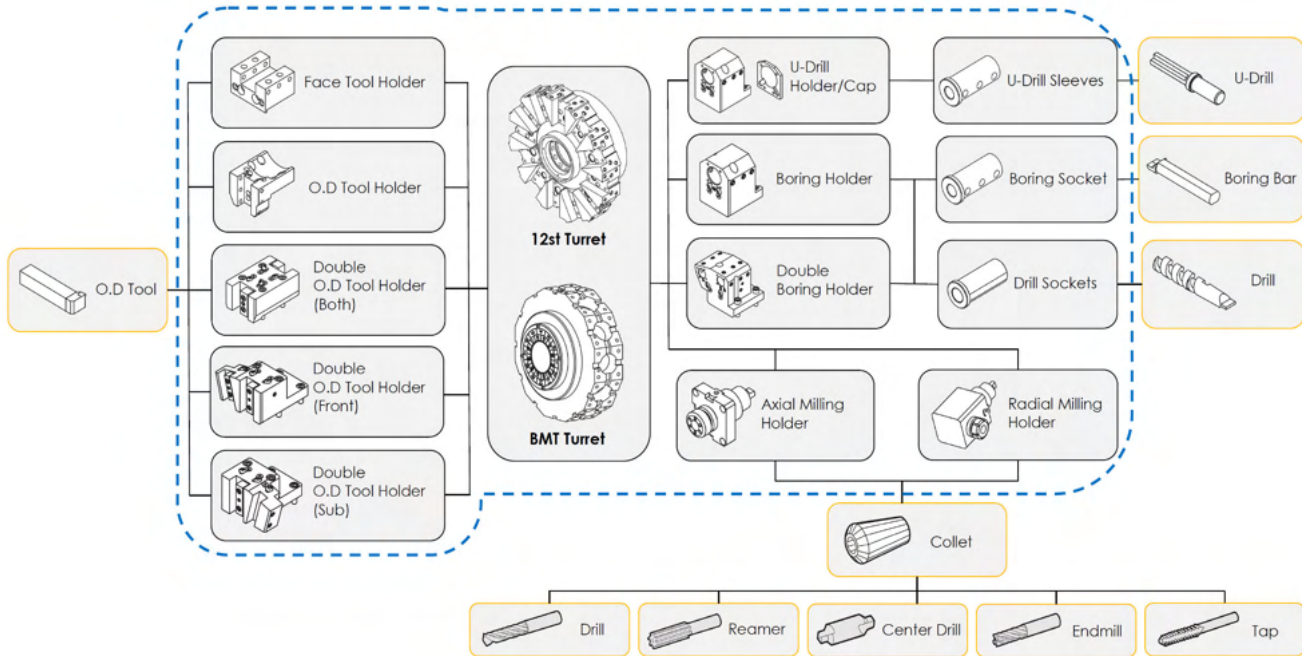

Standard Tooling Packages

Unit : mm (inch)

ITEM			NL 1500 NL 2000	NL 1500M NL 2000M	NL 2500 NL 3000	NL 2500M NL 3000M	NL 4000 NL 5000	NL 4000M NL 5000M	NL 6000	NL 6000M	NL 2000SY	NL 2500SY	
Turning Holder	O.D Holder	Single	-	3	-	3	1	4	1	4	1	1	
		Double(Both)	-	-	-	-	-	-	-	-	1	3	
		Double(Front)	-	-	-	-	-	-	-	-	1	1	
		Double(Sub)	-	-	-	-	-	-	-	-	1	-	
	Facing Holder	-	2	1	2	1	1	1	1	1	1	-	
Boring Holder	I.D Holder	Single	6	4	6	4	5	3	5	3	2	2	
		Double	-	-	-	-	-	-	-	-	1	1	
	U-Drill Cap	-	1	1	1	1	1	1	2	1	2	2	
Driven Holder	Axial Milling Holder	Standard	-	1	-	1	-	1	-	1	1	1	
	Radial Milling Holder	Standard	-	1	-	1	-	1	-	1	1	1	
Socket	Boring	Ø10(3/8")	1	1	1	1	-	-	-	-	1	1	
		Ø12(1/2")	1	1	1	1	1	1	-	-	1	1	
		Ø16(5/8")	1	1	1	1	1	1	1	1	1	1	
		Ø20(3/4")	2	2	2	2	1	1	1	1	1	1	
		Ø25(1")	2	2	2	2	1	1	1	1	1	1	
		Ø32(1 1/4")	2	2	2	2	1	1	1	1	1	1	
		Ø40(1 1/2")	-	-	2	2	1	1	1	1	1	-	1
		Ø50(2")	-	-	-	-	1	1	1	1	1	-	-
	Ø60(2 1/2")	-	-	-	-	-	-	-	1	1	-	-	
	Sub Boring	Ø10(3/8")	-	-	-	-	-	-	-	-	-	1	1
		Ø12(1/2")	-	-	-	-	-	-	-	-	-	1	1
		Ø16(5/8")	-	-	-	-	-	-	-	-	-	1	1
		Ø20(3/4")	-	-	-	-	-	-	-	-	-	1	1
Drill	MT2	1	1	-	-	1	1	1	1	1	1	-	
	MT3	1	1	1	1	1	1	1	1	1	1	1	
	MT4	-	-	1	1	1	1	1	1	1	-	1	
	MT5	-	-	-	-	-	1	1	1	1	-	-	

# NC Unit Specification/FANUC Series

● Standard features ○ Option

	ITEM	Specification	0i-TF
Controlled axis	Max. feed axes		4(6) Axis
	Feed axes		X/Z/Y/B (C, A)
	Max. simultaneously controlled axis		4
	Least command increment	0.001mm / 0.0001"	●
Operation functions	Pulse handle feed	X1, X10, X100	●
	Feedrate per minute	G98	●
	Feedrate per revolution	G99	●
Interpolation functions	Linear interpolation	G01	●
	Circular interpolation	G02, G03	●
	Dwell	G04	●
	Polar coordinate interpolation	G12.1, G13.1	●
	Cylindrical interpolation	G07.1	●
	Variable lead thread cutting	G34	●
	Continuous threading		●
	Reference position return	G28	●
Feed function	Reference position return check	G27	●
	Rapid traverse rate override	F0, 25%, 50%, 100%	●
Spindle function	Feedrate override	0 ~ 200%	●
	Spindle orientation		●
	Rigid tapping		●
Program input	Arbitrary speed threading		○
	Absolute/incremental programming		●
	Multiple repetitive canned cycle	G70 ~ G76	●
	Canned cycles	G90, G92, G94	●
	Inch/metric conversion	G20 / G21	●
	Program restart		●
	Retraction for rigid tapping		○
	Max. programmable dimension	±999999.999mm/±99999.9999	●
	M function	M3 digit	●
	Custom macro		●
	Canned cycle for drilling		●
	Direct drawing dimension programming		●
	Programmable data input	G10	●
	Optional block skip		●
	Workpiece coordinate system	G52 ~ G59	●
Number of registerable programs		400EA	
Setting and display	Alarm & Operator history display		●
	Run hour and parts count display		●
	Display spindle & servo overload		●
	Self-diagnosis function		●
	Extended part program editing		●
	Display screen		10.4" color
Data input/output	Memory card input/output		●
	USB memory input/output		●
Editing operation	Part program storage size	512 Kbyte (1280m)	●
Manual guide I	Manual guide I		○



## SMART Machine Tool Korea / R&D center / Factory

115-28, Techno valley 1-ro, Jillye-myeon, Gimhae-si,  
Gyeongsangnam-do, Republic of Korea

Tel: +82 55 342 7972 Fax: +82 55 342 7970

Email: smtk@smtkor.com

## SMART Machine Tool America

N25W23287 Paul Rd, Pewaukee, WI 53072, USA

Tel. +1 855 637 3220

Fax: +1 262 521 1244

www.smartmachinetool.com