

SMART
MACHINE TOOL

NX Series

BOX in BOX®

NX

NX 5000, NX 7000, NX 9000

UNRIVALED PERFORMANCE — HIGH PRODUCTION
HORIZONTAL MACHINING CENTER



**MADE BY
NIIGATA JAPAN**

SMART MACHINE TOOL, THE ORIGINATOR OF THE "BOX in BOX" CONCEPT, INTRODUCES THE 3rd/4th GENERATION NX SERIES — THE HIGHEST PERFORMANCE **NX5000/NX7000/NX9000** HORIZONTAL MACHINES

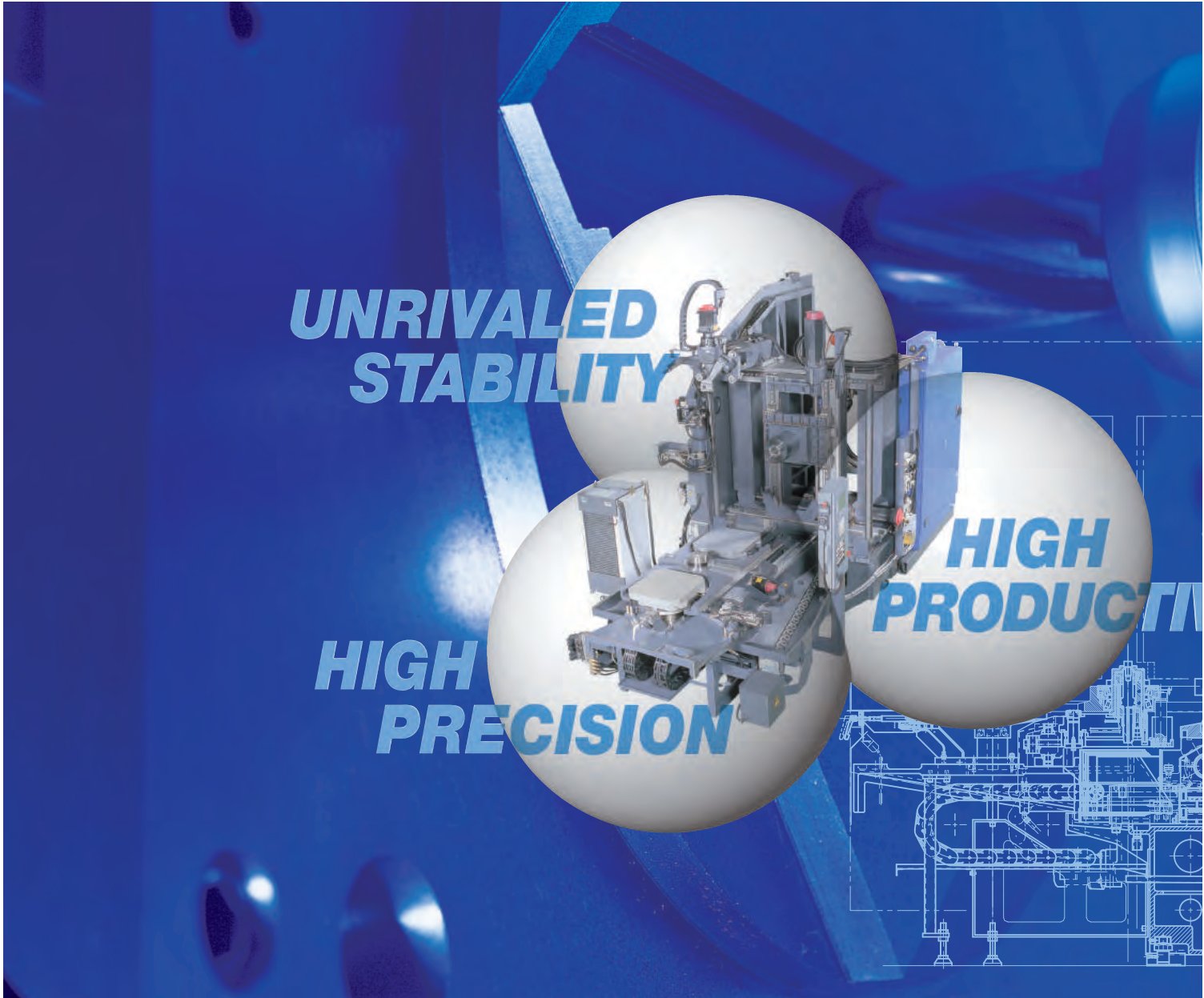

CONTENTS

BIG 3 FEATURES.....●2—●3
MAIN SPECIFICATION.....●4—●5
KEEPING LONG-TERM STABILITY.....●6—●7
HIGH PRECISION CUTTING.....●8—●9
HIGH PRODUCTIVITY.....●10—●13
WIDE RANGE OF OPTIONAL FEATURES.....●14—●15
MACHINE DIMENSIONS.....●16—●21
SPECIFICATIONS.....●22—●23

BOX[®] DESIGN, HIGH PERFORMANCE MACHINING CENTERS



Building on a century of machine tool design and innovation, SMART Machine Tool is proud to be recognized as a leader and specialist in horizontal machining centers. SMART Machine Tool's renowned "BOX in BOX[®]" NX Series machines were introduced in 1993 and have earned the global respect as the VALUE leader. As a compliment to SMART Machine Tool's intelligent design, there are a growing number of imitators.

However, those who try to copy or mimic SMART Machine Tool, can not match the functionality of the components which work in harmony in the NX Series machines. While others try to "catch-up", SMART Machine Tool continues to innovate in introducing the 3 model NX series.

- The casting design, the leading linear roller-guide way system, the unique reliable tool changer, and the spindle cutting capability are designed to allow you to achieve your goal of accurate parts produced in the shortest time.
- Dependable, repeatable, long-term stability is achieved in the stationary column design.
- The innovative casting design yields industry's most rigid "T-shaped" base – enabling the use of a 3-point contact with your floor, and more accurate machining.
- The most reliable tool changer, SMART Machine Tool's Synchronous Swing Motion (SSM) ATC continues to give you years of fast dependable performance.
- 8000, 10000, 12000, 15000 min⁻¹(rpm) spindles give you the choice to fit your application.



SMART MACHINE TOOL'S ORIGINAL THINKING AND CONTINUED INNOVATION WILL YIELD THE GREATEST VALUE IN HIGH SPEED HORIZONTAL MACHINES INTRODUCING THE LATEST "NX" FAMILY

NX 5000

Travel	X axis:	800 mm (31.5")
	Y axis:	750 mm (29.5")
	Z axis:	750 mm (29.5")

Pallet Size	500 × 500 mm (19.7" × 19.7")
-------------	---------------------------------

Maximum Work Piece	
Swing diameter:	800 mm (31.5")
Height:	1000 mm (39.4")

Spindle Speed	8000 min ⁻¹ ~ 15000 min ⁻¹ (rpm)
---------------	--

Spindle Power	AC30 kW (40 HP) ~ AC45 kW (60 HP)
---------------	-----------------------------------

Rapid Traverse (X, Y, Z axis)	50 m/min (1968 ipm) OP: 61 m/min (2400 ipm)
----------------------------------	--

High Torque Spec. and High Power Spec. Spindle are available — See page 12.



NX 5000

CONTINUOUS IMPROVEMENTS IN MACHINING CENTERS

NX 7000

1000 mm (39.4")
950 mm (37.4")
850 mm (33.5")

630 × 630 mm
(24.8" × 24.8")

1100 mm (43.3")
1200 mm (47.2")

60 m/min (2362 ipm)

NX 9000

1500 mm (59.1")
1300 mm (51.2")
1150 mm (45.3")

800 × 800 mm
(31.5" × 31.5")

1750 mm (68.9")
1400 mm (55.1")

50 m/min (1968 ipm)

- EXCELLENT CHIP EVACUATION
- HUGE WORK ENCLOSURES
- CONVENIENT WORK PLATFORM



NX 9000

SMART MACHINE TOOL ORIGINATED THE "BOX in BOX"™ MAC OPTIMUM CUTTING PERFORMANCE AND LONG-TERM STAB INTRODUCING THE **NX** SERIES — *the INNOVATION CONTINU*

NX 5000/7000/9000

UNRIVALED STABILITY



THE INNOVATIVE "NX" DESIGN BEGINS WITH THE "BOX in BOX"™ STRUCTURE, ORIGINATED BY SMART MACHINE TOOL.

The stationary "one-piece" column is mounted on a rigid T-shaped "mono-cast" base. This is the heart of machine squareness, which is so critical in achieving accurate machining. Mount the spindle carrying saddle to the column and the goal of practical long-term high speed movement is realized.

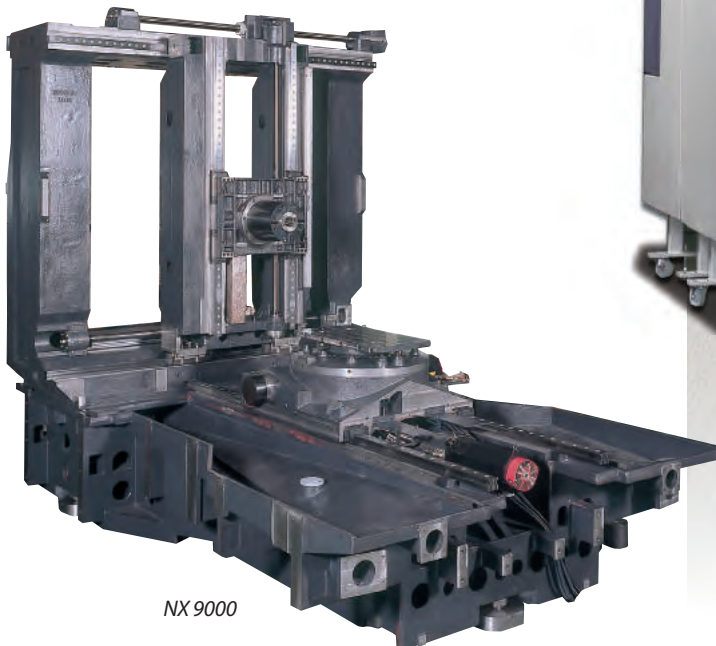

NX 9000



NX 5000

**CHINE DESIGN TO PROVIDE HIGH-SPEED,
ABILITY.
NES —**



ULTRA RIGID CONSTRUCTION

BOX in BOX®

- Stationary column fixed directly to machine base yields increased cutting capability at top of Y-axis stroke.
- Way mounting surfaces are machined and ground flat to assure optional alignment and accuracy.
- Lower rail mounted perpendicular to upper rail allows mass of spindle saddle to be supported fully thereby increasing rigidity and accuracy.
- Reduced mass of spindle headstock assembly contributes to lower maintenance and a longer service life.

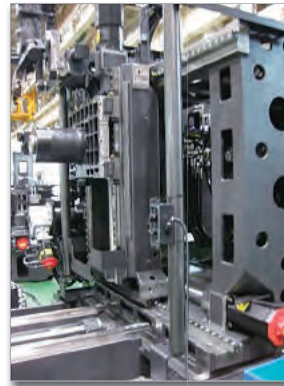

- Mass of Moving Body (Spindle Saddle) is as Light as 1/3.
- Absolute Wide Guide Span
- Rigid Saddle
- High Output Spindle is Vertically Guided at Center of Gravity.
- Fixed Column and Z-guide Face is Ground Finished by Gantry Bed Grinder.

THREE POINT BASE CASTING

- Honeycomb design improves structural rigidity.
- Solid base structure allows for simple 3-Point leveling.

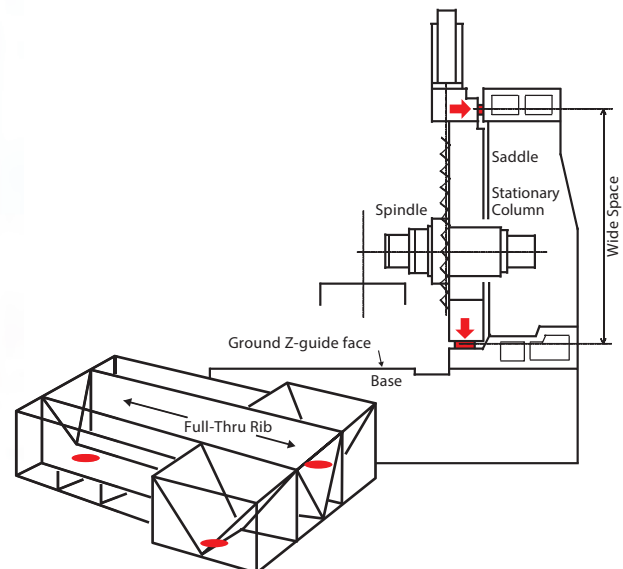

SMART MACHINE TOOL HIGH PRECISION CUTTING

NX 5000/7000/9000

SMART
PRECISION

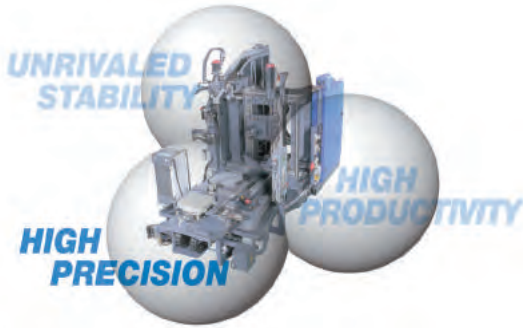

SMART MACHINE TOOLS "BOX in BOX"® DESIGN ENSURES LONG-TERM STABILITY OF MACHINE ACCURACY

Here is the data to proof unrivaled stability of machine accuracy. It is basically no change of the machine accuracy after 3 years of the machine installation.

EXACTING ACCURACY (ACCURACY OF CIRCULAR INTERPOLATION)

	NX 5000	NX 9000
Roundness..... (Tolerance)	10 μm (0.0004")	10 μm (0.0004")
Roundness..... (Actual record)	2.8 μm (0.00011")	2.2 μm (0.00009")

● Cutting Data (NX 5000 / 9000)

Material..... A5052
 Diameter..... φ218 mm {8.58"}
 Cutting tool..... φ16 mm {0.62"} end mill 4T Carbide

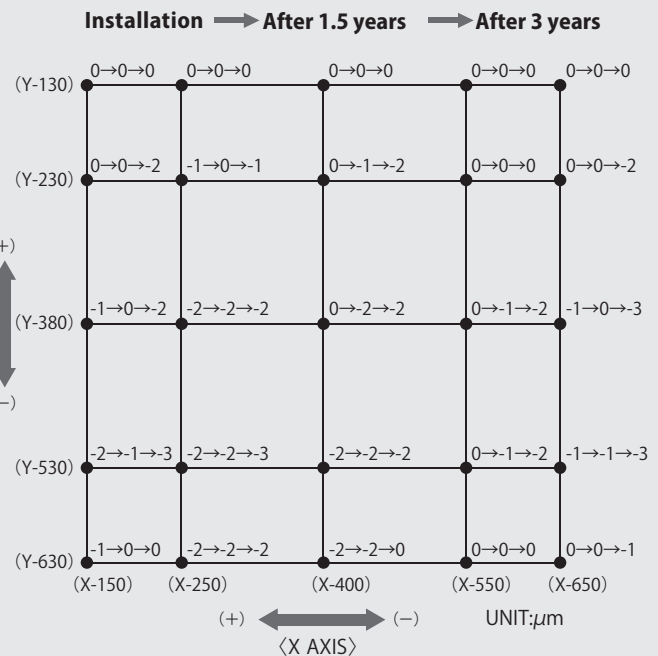
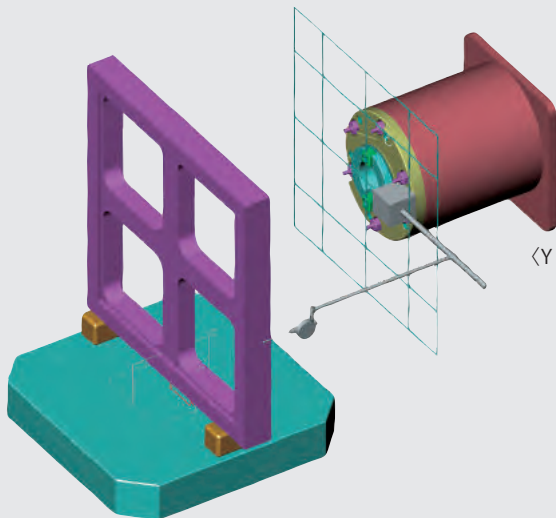
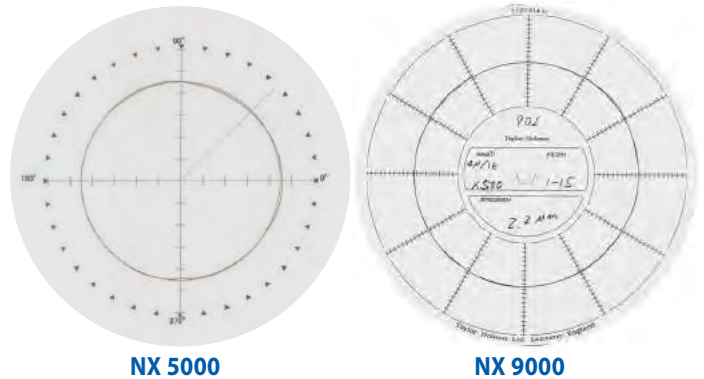

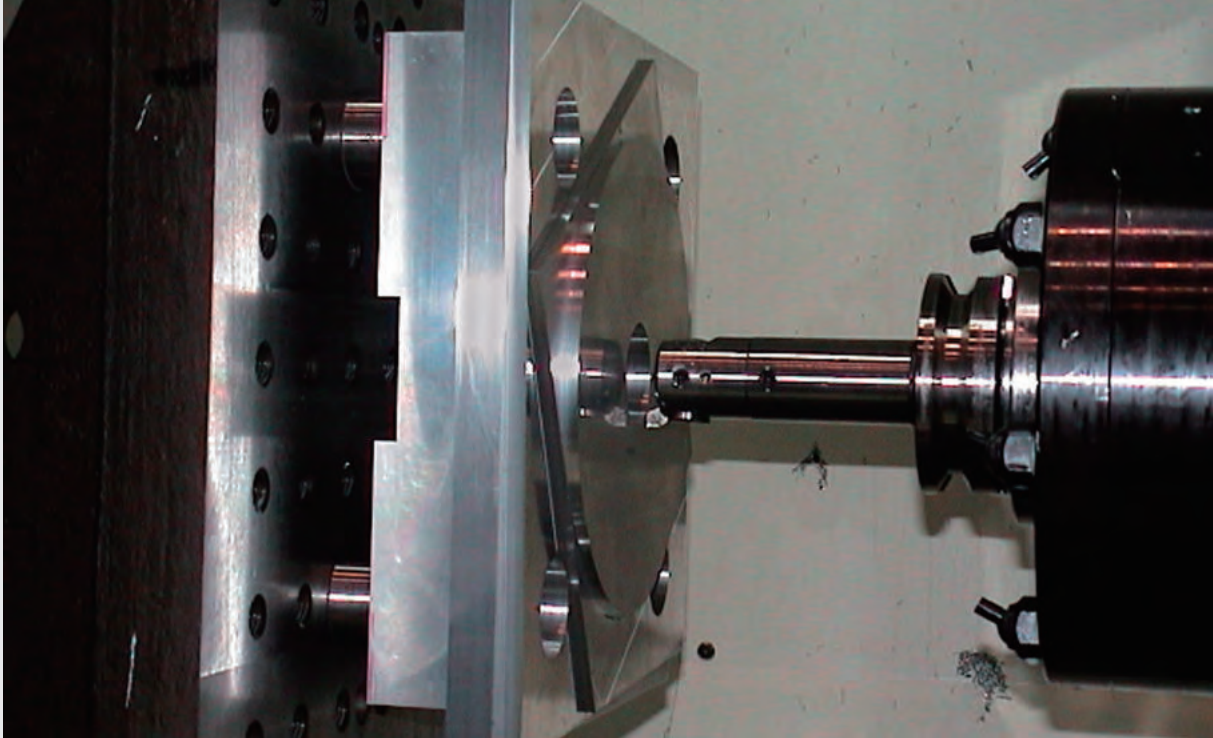

EXACTING ACCURACY (Cutting data by NX 5000/NX9000 with scale feedback system)

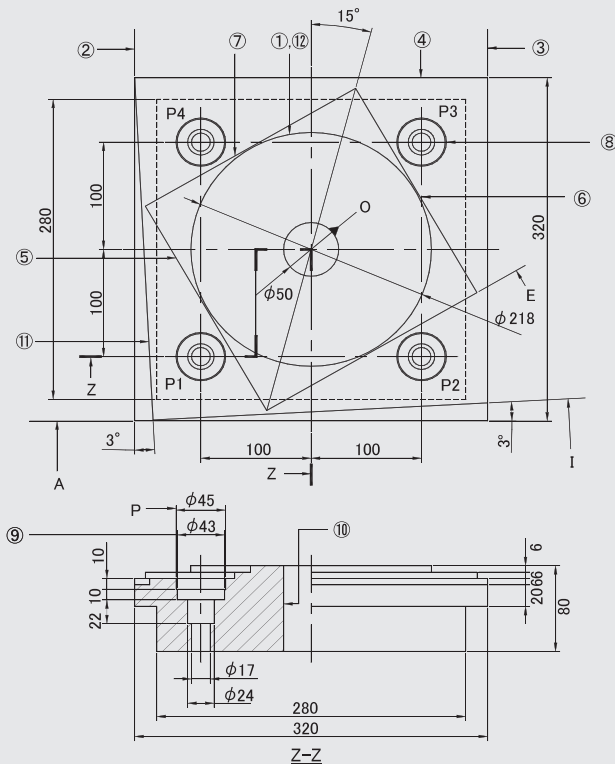

Cutting accuracy (μm)

Items	NX 5000	NX 9000
① Roundness	3.8	2.2
② Squareness (A)	3	3
③ Squareness (A)	6	2
④ Parallelism (A)	1	1
⑤ Squareness (E)	1	6
⑥ Squareness (E)	1	1
⑦ Parallelism (E)	1	7
⑧-P1 Position error (O)	7	8
⑧-P2 Position error (O)	8	6
⑧-P3 Position error (O)	2	4
⑧-P4 Position error (O)	8	0
⑨-P1 Concentricity (8-P1)	1	4
⑨-P2 Concentricity (8-P2)	6	1
⑨-P3 Concentricity (8-P3)	2	2
⑨-P4 Concentricity (8-P4)	3	2
⑩ Cylindricity	7	3
⑪ Squareness (I)	2	0
⑫ Concentricity (O)	8	5

SMART MACHINE TOOL'S INNOVATION LEADS TO HIGH SPEED, HIGH PRODUCTIVITY

NX 5000/7000/9000

*HIGH
PRODUCTIVITY*



SMART MACHINE TOOL'S UNIQUE SYNCHRONOUS SWING MOTION (SSM) AUTO TOOL CHANGING SYSTEM.....①

For high speed and weight the SSM has proven to be the most reliable tool exchange mechanism. It employs Fanuc servo technology to achieve ease of maintenance and operator friendliness.

ATC Time (Exclude ATC shutter open/close time)

NX 5000 (Tool weight 20 kg {40 lbs})

T to T...1.4 s C to C...3.8 s

NX 7000 (Tool weight 20 kg {40 lbs})

T to T...1.4 s C to C...3.8 s

NX 9000 (Tool weight 30 kg {66 lbs})

T to T...2.7 s C to C...5.8 s

SYNCHRONOUS SWING MOTION (SSM) ATC

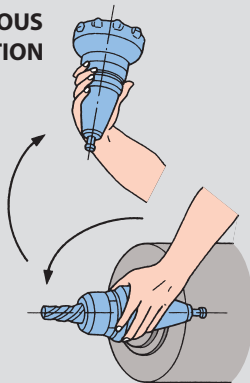

(For NX 9000 only)

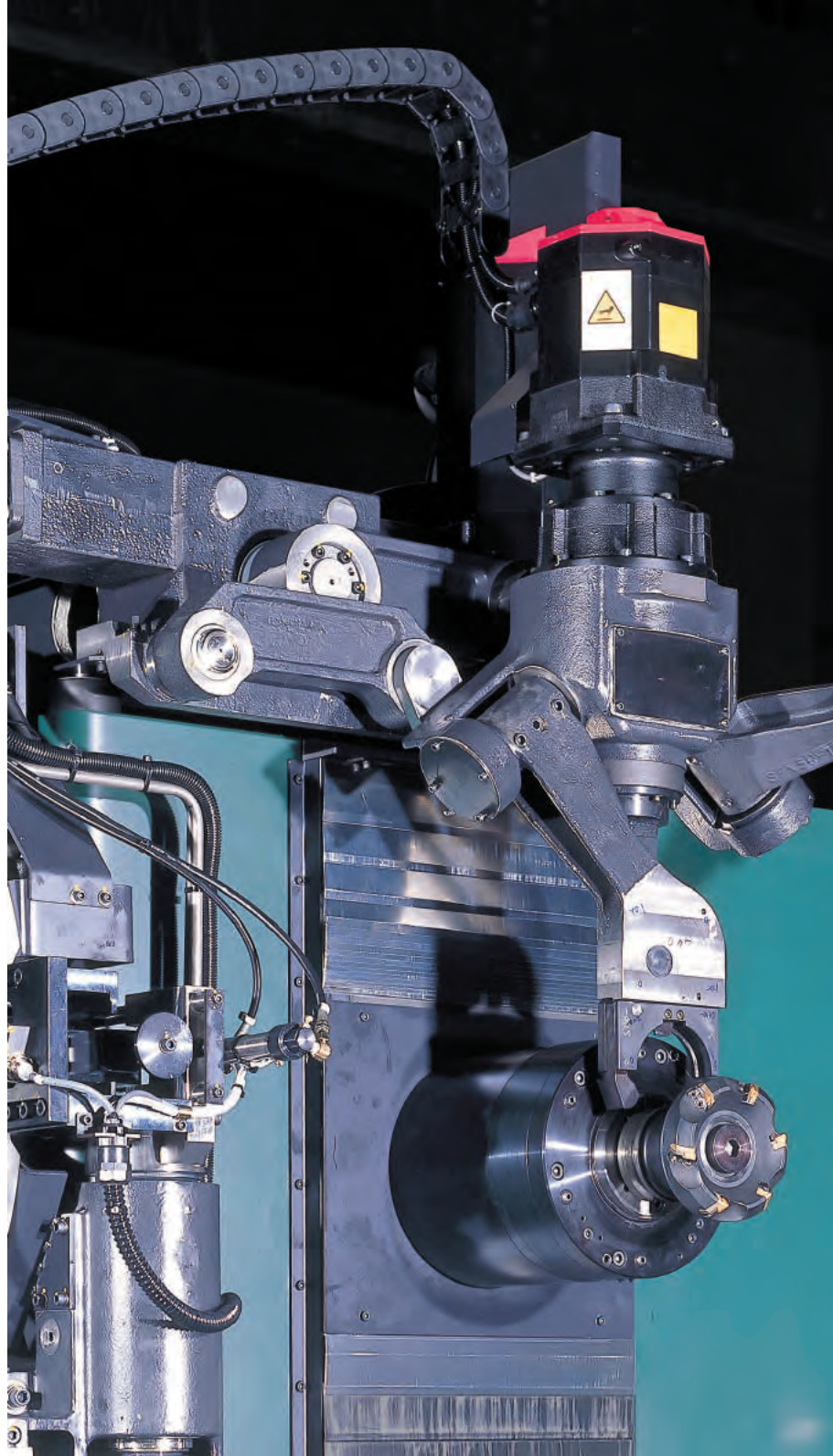

1

**SHORTER CYCLE TIME
DELIVERS
HIGH PRODUCTIVITY**

NX 5000

- Rapid traverse

50 m/min
(1968 ipm)

- Option

61 m/min
(2400 ipm)

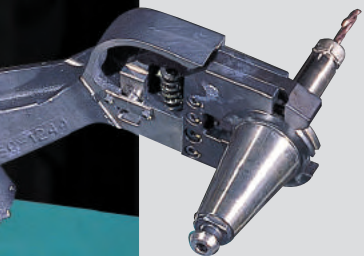

NX 7000

- Rapid traverse

60 m/min
(2362 ipm)

NX 9000

- Rapid traverse

50 m/min
(1968 ipm)

SELF LUBRICATION FUNCTION 2

Long duration lubrication designed into the ball nut and linear roller truck means lower operating cost and responsibility to the environment.

**ULTRA RIGID AND HIGH LOAD
TYPE OF ROLLER GUIDE WAY
SYSTEM**.....3

To maximize rigidity and dampening, roller bearing guides are adopted on the X, Y and Z axes.

The combined engineering features, such as enhanced rigidity of the machine construction, wider span of the X and Y axes guide ways, and the roller guide way system meet rigorous production needs.

The roller bearings are guided with roller retainers resulting in no roller-to-roller contact and less friction.

**DESIGN DETAILS FOCUSES ON
OPERATOR FRIENDLINESS**.....4

The operator panel is positioned to the left side of operator door giving excellent accessibility and ease of operation.

The manual pulse generator has XYZ axis coordinate display by LCD as an option.

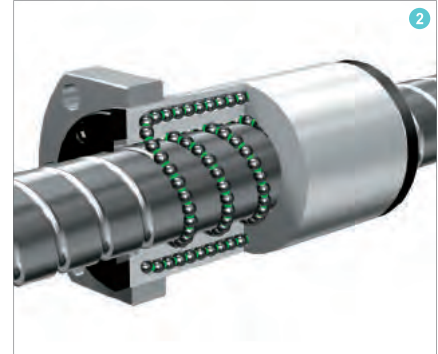

**DURABLE WAY COVERS FOR
HIGH SPEED POSITIONING**.....5

It is simple, yet effective. The heat-resistant durable covers are interconnected providing uniform movement with spindle- saddle.

- No collision parts. Fast and silent
- Durable and smooth movement
- Cover is one sheet, Minimizes coolant and/or swarf escape.

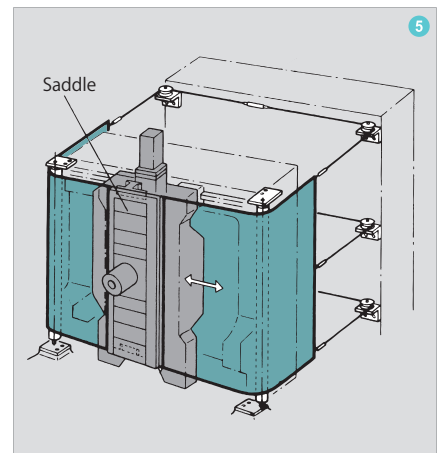

NX 5000/7000/9000

— HIGH PRODUCTIVITY

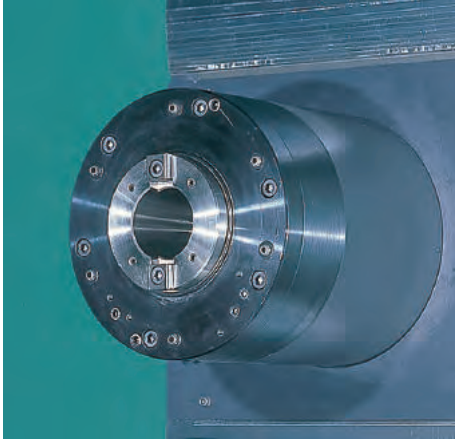

VARIETY OF HIGH PERFORMANCE SPINDLES

The spindle of performance is one of key evidence of the capability of the machine. The spindles provide Speed, Power, and Accuracy for full range of cutting conditions. 8000 min⁻¹ (rpm), 10000 min⁻¹ (rpm), 12000 min⁻¹ (rpm), 15000 min⁻¹ (rpm) / High Power Spec., and 8000 min⁻¹ (rpm) / High Torque Spec. are also available.

	1 10000min ⁻¹ (rpm)	2 12000min ⁻¹ (rpm)	3 8000min ⁻¹ (rpm)	4 15000min ⁻¹ (rpm) High Power Spec.	5 8000min ⁻¹ (rpm) High Torque Spec.
	•Spindle Power 30kW {40HP} •Max.Torque 420N·m{310ft·lbs}	•Spindle Power 30kW {40HP} •Max.Torque 420N·m{310ft·lbs}	•Spindle Power 30kW {40HP} •Max. Torque 600N·m{442ft·lbs}	•Spindle Power 45kW {60HP} •Max. Torque 400N·m{295ft·lbs}	•Spindle Power 37kW {50HP} •Max. Torque 1009N·m{744ft·lbs}
NX 5000	Standard	Option	Option	Option	N/A
NX 7000	N/A	Standard	Option	Option	Option
NX 9000	N/A	N/A	Standard	Option	Option

SPINDLE SPEED AND TORQUE DIAGRAM

1,2 10000/12000 min⁻¹ SPINDLE (5000, 7000)

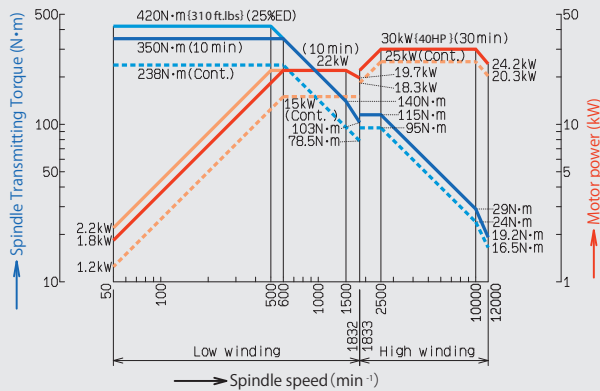

4 15000 min⁻¹ SPINDLE High Power Spec. (5000, 7000, 9000)

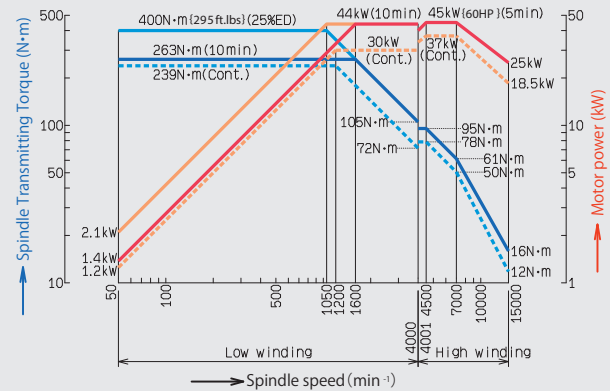

3 8000 min⁻¹ SPINDLE (5000, 7000, 9000)

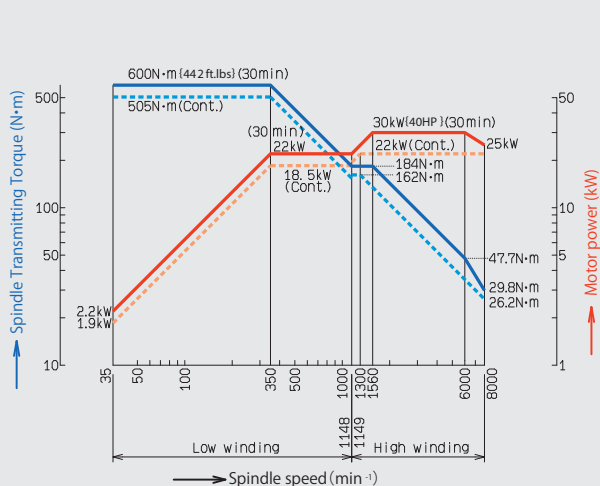

5 8000 min⁻¹ SPINDLE High Torque Spec. (7000, 9000)

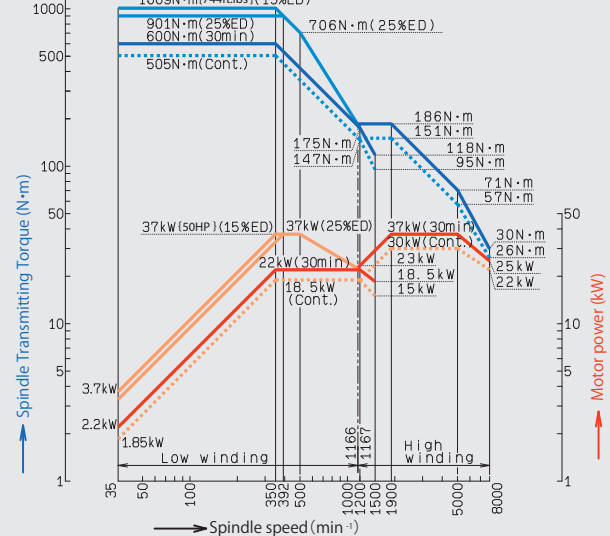

SPINDLE CONSTRUCTION

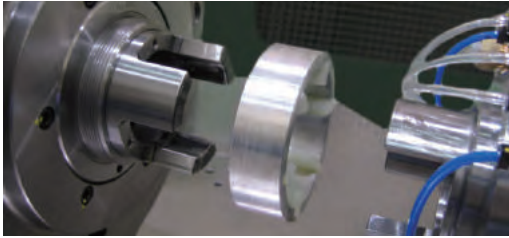

EXAMPLE SPN'S MACHINING PERFORMANCE

•Milling Cutter — **NX 5000** Spindle 10000 min⁻¹ (rpm)

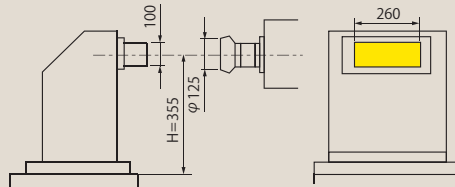
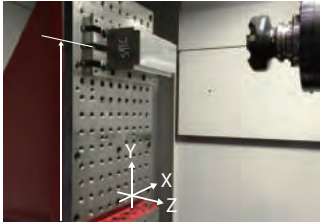

- Material: S48C •Tool: φ125×6T
- Cutting volume: 458 cm³/min (27.9 in³/min)
- Cutting depth: 4 mm (0.157")
- Cutting width: 100 mm (3.93")
- Feedrate: 1146 mm/min (45.1 ipm)
- Spindle Speed: 637 min⁻¹ (637 rpm)
- Surface Speed: 250 m/min (820 SFM)

•Milling Cutter — **NX 7000** Spindle 12000 min⁻¹ (rpm)

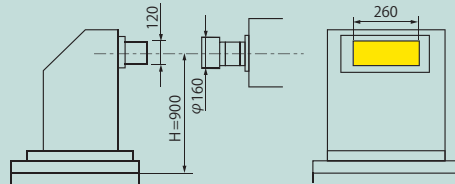

- Material: S45C •Tool: φ160×8T
- Cutting volume: 493 cm³/min (29.9 in³/min)
- Cutting depth: 6 mm (0.24")
- Cutting width: 120 mm (4.72")
- Feedrate: 686 mm/min (27.0 ipm)
- Spindle speed: 400 min⁻¹ (400 rpm)
- Surface Speed: 200 m/min (656 SFM)

•Drilling — **NX 7000** Spindle 12000 min⁻¹ (rpm)

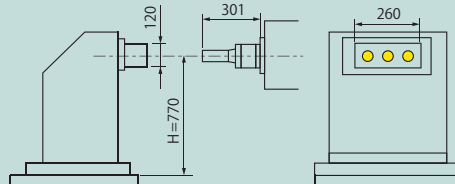
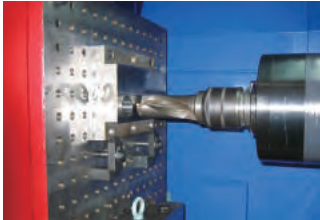

- Material: S45C
- Tool: φ60 insert style drill
- Spindle load: 66%
- Zaxis load: 77%
- Feedrate: 95 mm/min (3.7 ipm)
- Spindle speed: 795 min⁻¹ (795 rpm)
- Surface Speed: 150 m/min (492 SFM)

•Milling Cutter — **NX 9000** Spindle 8000 min⁻¹ (rpm)

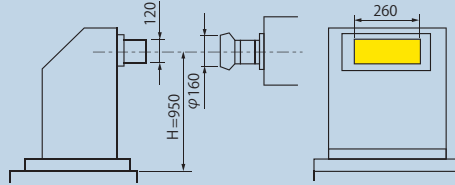
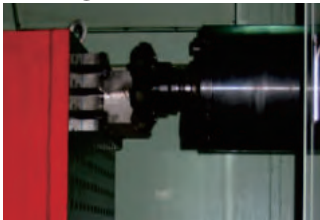

- Material: S45C •Tool: φ160×8T
- Cutting volume: 700 cm³/min (42.7 in³/min)
- Cutting depth: 6 mm (0.24")
- Cutting width: 120 mm (4.72")
- Feedrate: 980 mm/min (38.6 ipm)
- Spindle speed: 350 min⁻¹ (350 rpm)
- Surface Speed: 176 m/min (577 SFM)

•Drilling — **NX 9000** Spindle 8000 min⁻¹ (rpm)

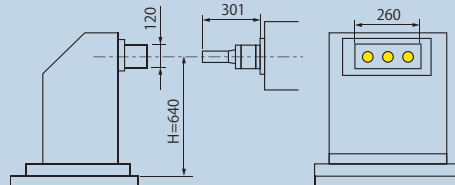

- Material: S45C
- Tool: φ60 insert style drill
- Spindle load: 60%
- Zaxis load: 30%
- Feedrate: 95 mm/min (3.7 ipm)
- Spindle speed: 795 min⁻¹ (795 rpm)
- Surface Speed: 150 m/min (492 SFM)

WIDE RANGE OF OPTIONS TO ANSWER YOUR INDIVIDUAL MACHINING REQUIREMENTS

STANDARD EQUIPMENT

- Automatic Tool Changer With
62 ATC Tool Capacity (NX 5000)
60 ATC Tool Capacity (NX 7000/9000)
- Direct Drive Spindle
50 -10000 min⁻¹ (rpm) (NX 5000)
50 -12000 min⁻¹ (rpm) (NX 7000)
35 -8000 min⁻¹ (rpm) (NX 9000)
- Spindle Cooling Unit
- One Degree Indexing Table
- Direct Turn Type Twin Pallet Change System With Idle Self Rotation (NX 5000 / NX 7000)
- Rotary Shuttle Type Pallet Change System With Walk Around Platform (NX 9000)
- Chip Augers Built into the Bed
- Flood Coolant System
- Full Enclosure-Type Splash and Chip Guarding System
- Work Completion and Emergency Lamp
- Fanuc CNC System
- 10.4" Color LCD
- Rigid Tapping
- Spindle Load/Speed Meter display on CNC Screen
- Self Diagnostics Function

OPTIONAL FEATURES

FIELD EXPANDABLE ATC MAGAZINE (NX 5000)

SMART Machine Tool's exapandle ATC magazine was designed to comply with requirements to increase tool storage capacity on existing equipment at the field.

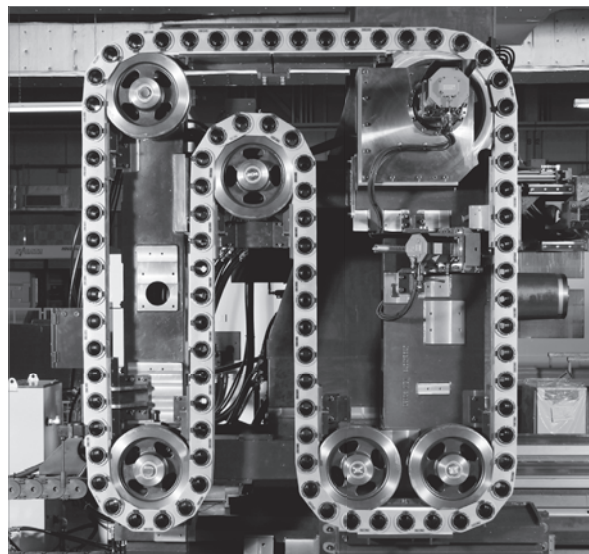

OPTIONAL FEATURES

AXIS FEEDBACK SYSTEM

- Scale Feedback System on XYZ Axes (Optical Scale Type)
- Scale Feedback System on B axis (NC table)

ATC MAGAZINE(Field Expandable)

- 88 /128 Tool Magazine (NX 5000 only)
- Matrix Style ATC System (126 / 178 / 230 /308)

TABLES

- 0.001° (NC Table) /4th Axis Continuous
- 5 Axis Application (Table on Table)

PALLET and PALLET CHANGER SYSTEM

- Carousel Type Multiple Pallet Changer 6 /8 /10 /12 APC (only 6 and 8 APC for NX 9000)
- Linear Pallet Magazine System with Niigata ICC System Controller
- Additional Pallet
- T-slotted pallet (Tapped Hole pattern with edge locator is Standard / Restriction of Max Load on Pallet may apply)

COOLANT SYSTEM

- Spindle Center Through Coolant
- Spindle Flange Through Coolant
- Overhead Shower Coolant System

- Shower Coolant and Airblow Function
- Work piece Washing Gun
- Coolant Low Level Sensing Device

CHIP REMOVAL

- Hinge Type Lift-Up Conveyor
- Lift-Up External Conveyor with Filtration System
- Chip Bucket with Caster and Handles

MONITORING FUNCTION

- Advanced Unmanned Monitoring System / SMART MACHINE TOOL MONITOR ACE
- Spindle Probe
- Table Probe

- Tool Breakage Detector NSP/LSZ Type
- 4 Face Part Program Control Function

SPINDLE

- BIG PLUS Spindle (only for 12000 rpm and 8000 rpm)
- 15000 min⁻¹ (rpm) 45 kW (60 HP) Spindle
- 8000 min⁻¹ (rpm) 30 kW (40 HP) High Torque Spindle (NX 5000 and NX 7000 only)
- OP: 15" LCD new HMI Main operation panel

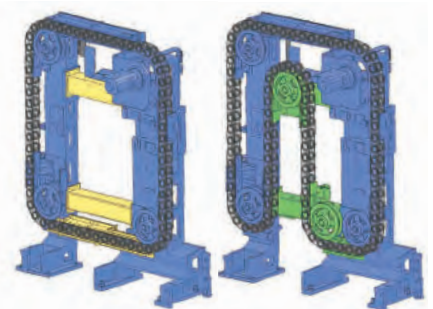

62 Tools *Standard*

88 Tools *Optional*

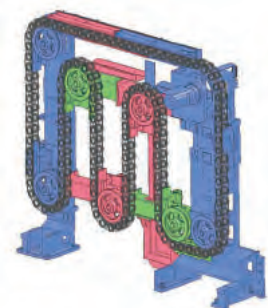

128 Tools *Optional*

MATRIX TYPE AUTOMATIC TOOL CHANGE SYSTEM

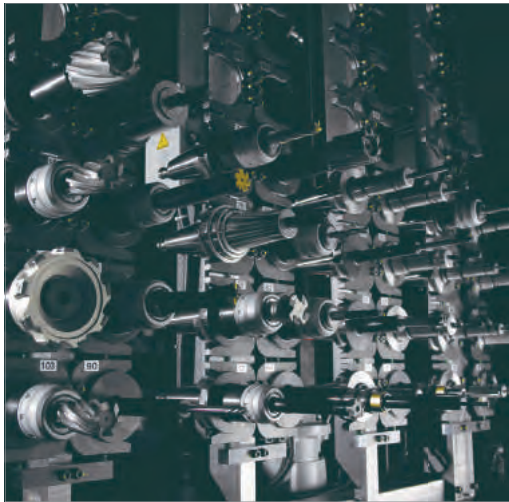

HIGH PRESSURE TYPE COOLANT THROUGH SPINDLE SYSTEM

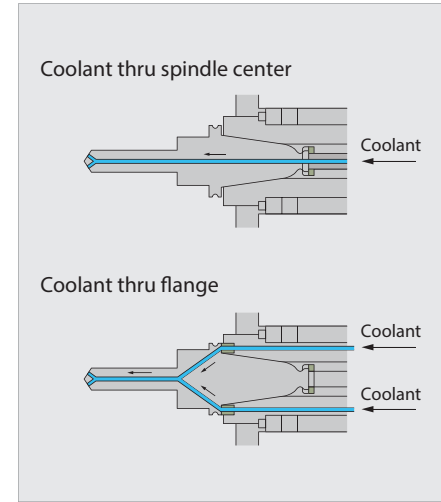

LIFT-UP EXTERNAL CONVEYOR WITH FILTRATION SYSTEM (NX 9000)



CHIP CONVEYOR REAR/SIDE BOTH OPTIONS ARE AVAILABLE



ADVANCED UNMANNED MONITORING SYSTEM SMART MACHINE TOOL MONITOR ACE (NM24 Generation II)



KEY FEATURES

- Display on machine operational screen: All main features shown on machine operational screen (FANUC CNC control)
- Cutting monitor–Max Spindle load monitor / Adaptive Control / Axis load monitor / Feed rate monitor: Set the reference data of spindle load / Axis load and monitor the actual data during the machine run to minimize cutting Issues as well as machining of defective parts.
- Tool Life Monitor / Spare Tool Function: Set life time value on each tool and monitor the actual time used. The alarm occurs when the time of use

- reaches the set value. Automatic change of the tool to alternative tool is available when spare tool is ready.
- Automatic Continuous Machine Run: Automatically proceed to the next work piece after the monitoring system detects some alarm condition on current process.
- Tool Number Conversion: Eight (8) digits tool number is available as a standard function.

THE "BOX in BOX[®]" MACHINE LAYOUT

— **NX 5000**

MAXIMUM WORKPIECE ENVELOPE

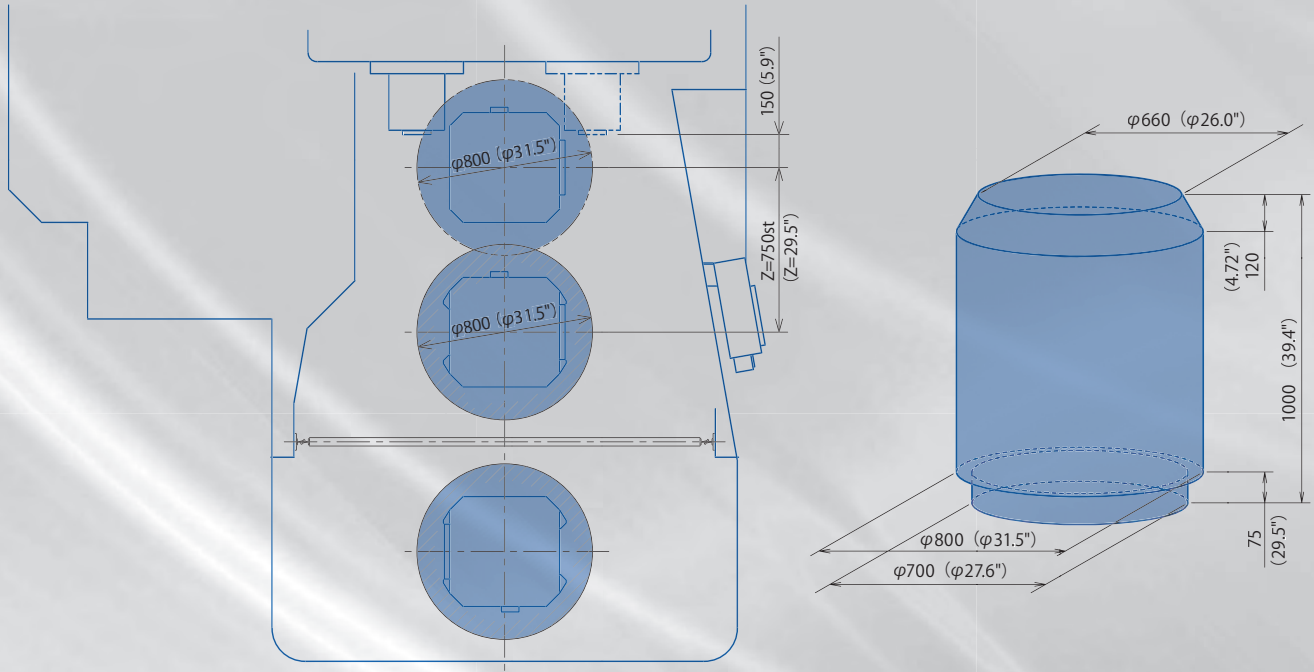

STANDARD PALLET TOP SURFACE

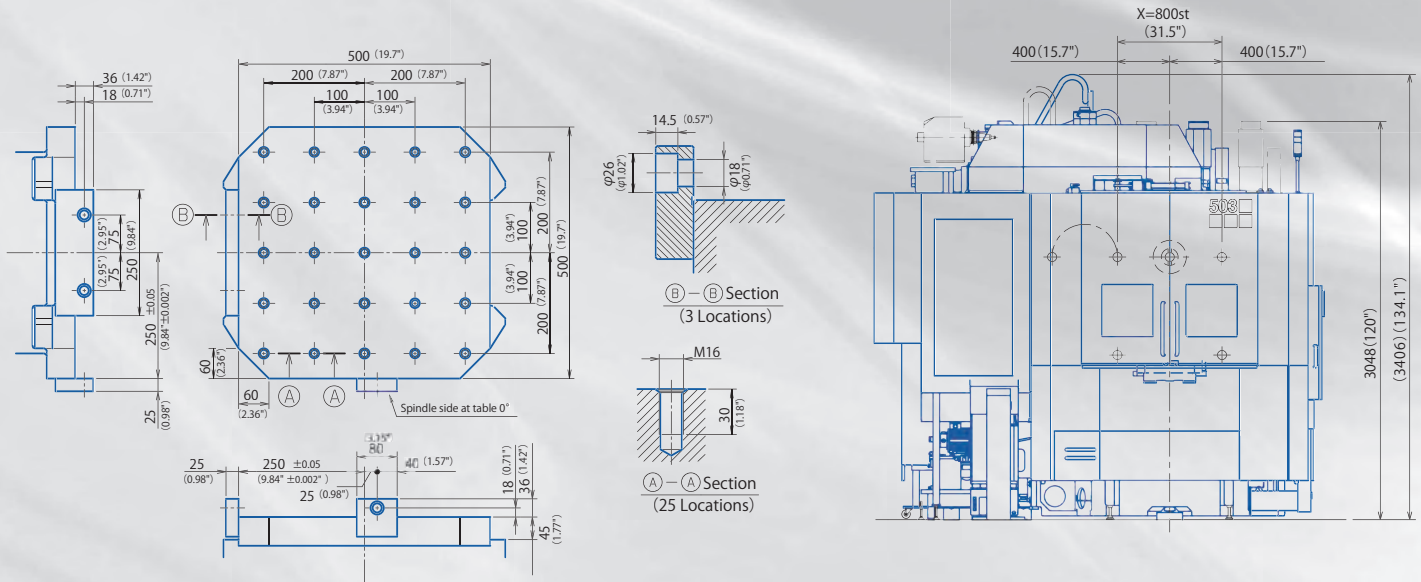

NX 5000 GENERAL VIEW MM(INCH)

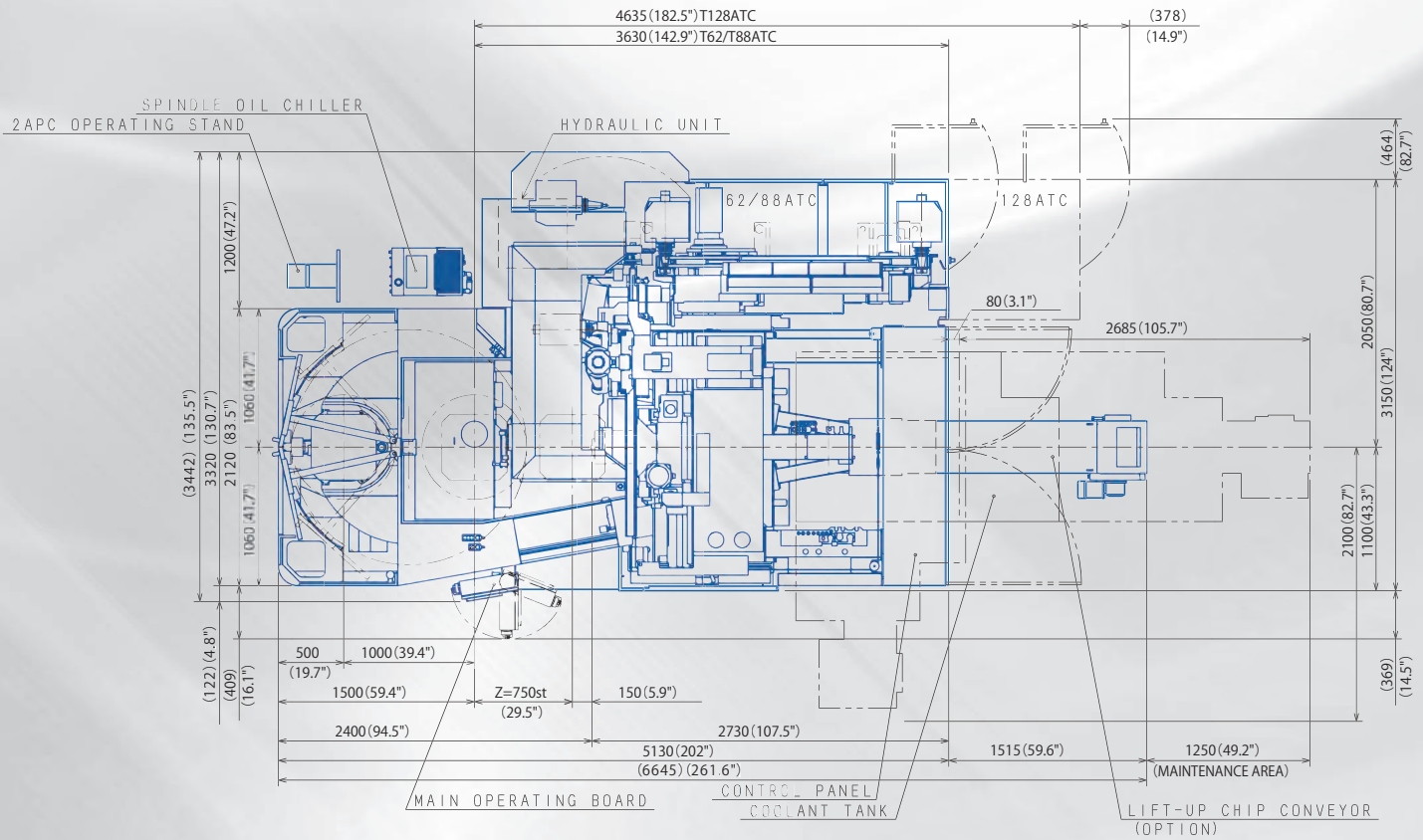

NOTE: Dimensions shown for Rear Discharge only. Side discharge is also available.

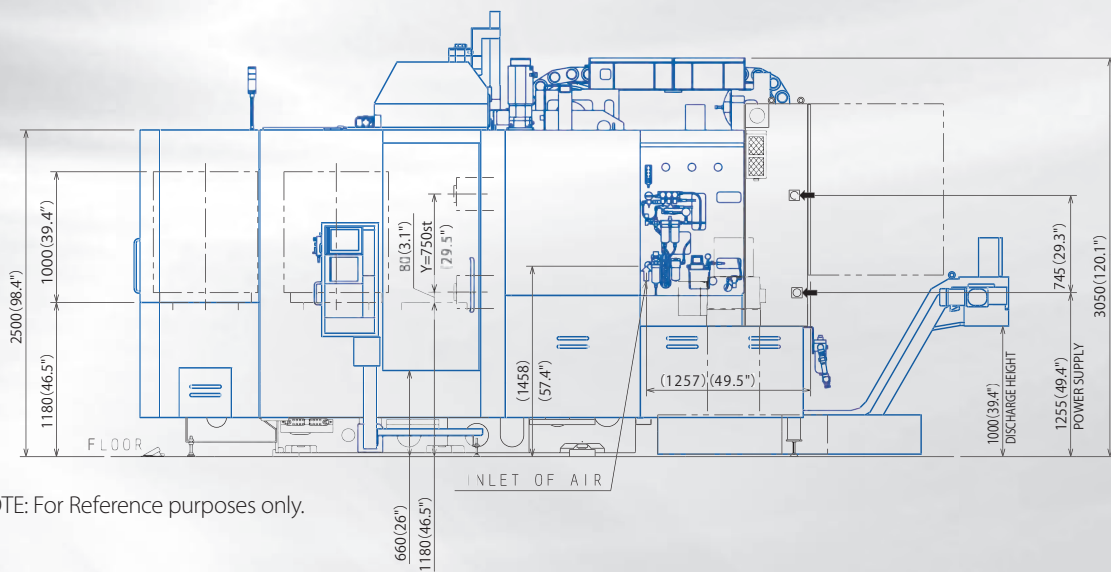

NOTE: For Reference purposes only.

THE "BOX in BOX[®]" MACHINE LAYOUT

— **NX 7000**

STANDARD PALLET TOP SURFACE

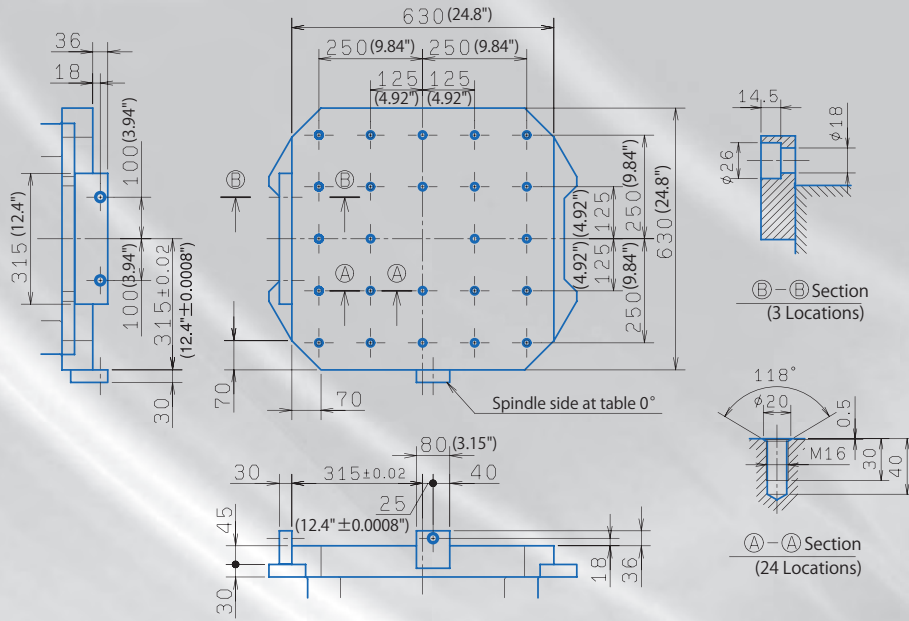

NX 7000 GENERAL VIEW MM(INCH)

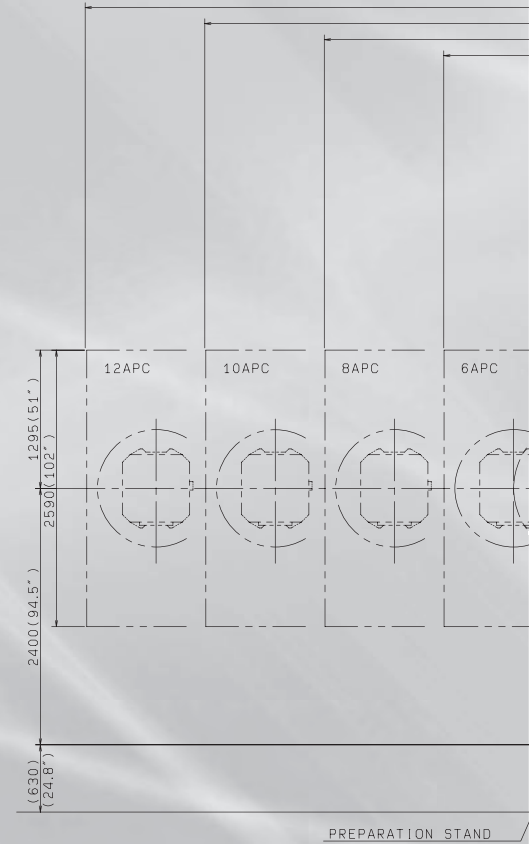

MAXIMUM WORKPIECE ENVELOPE

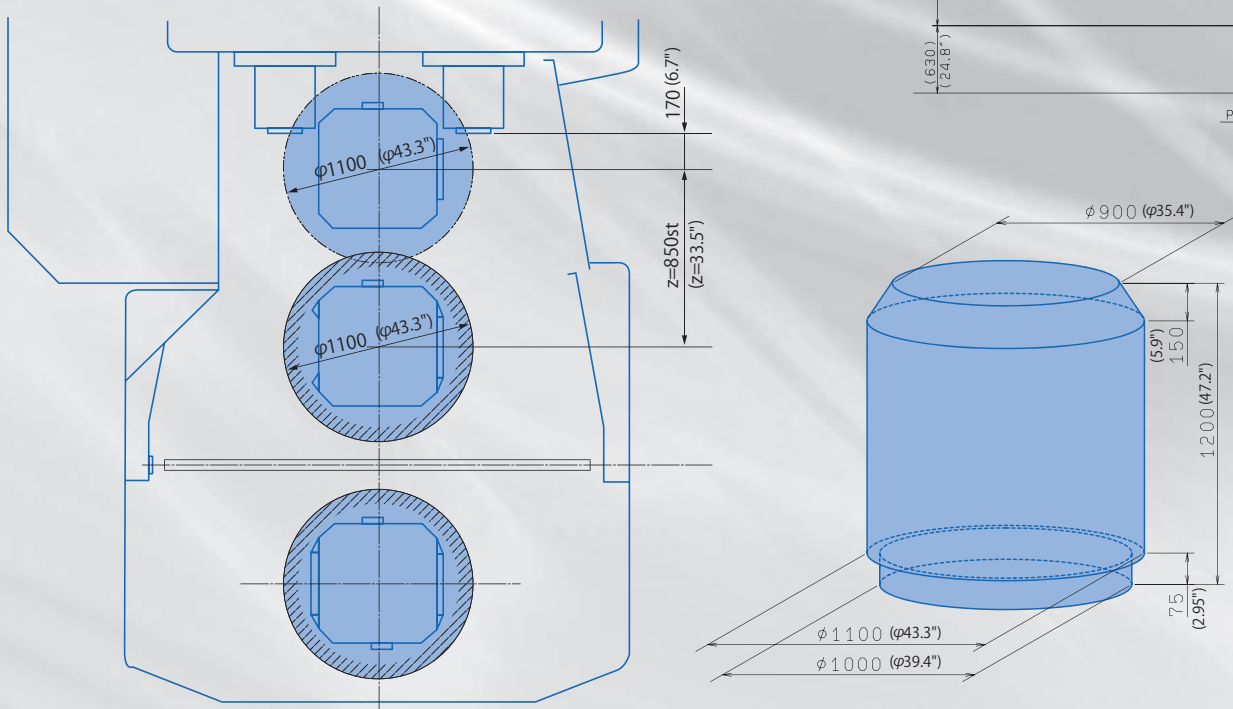

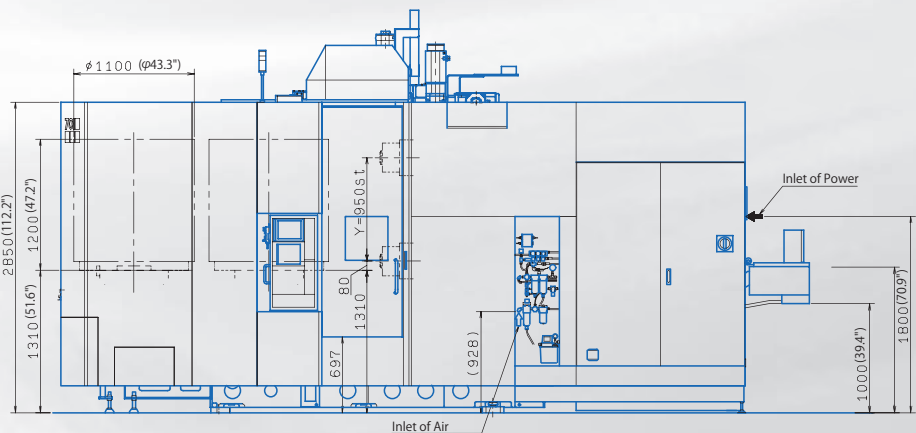
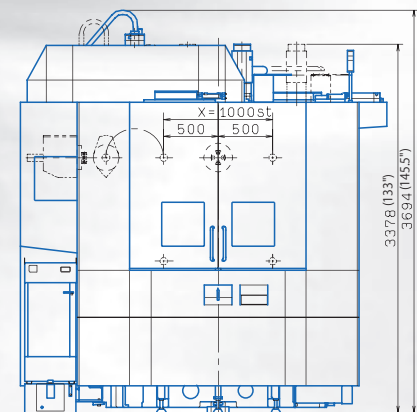
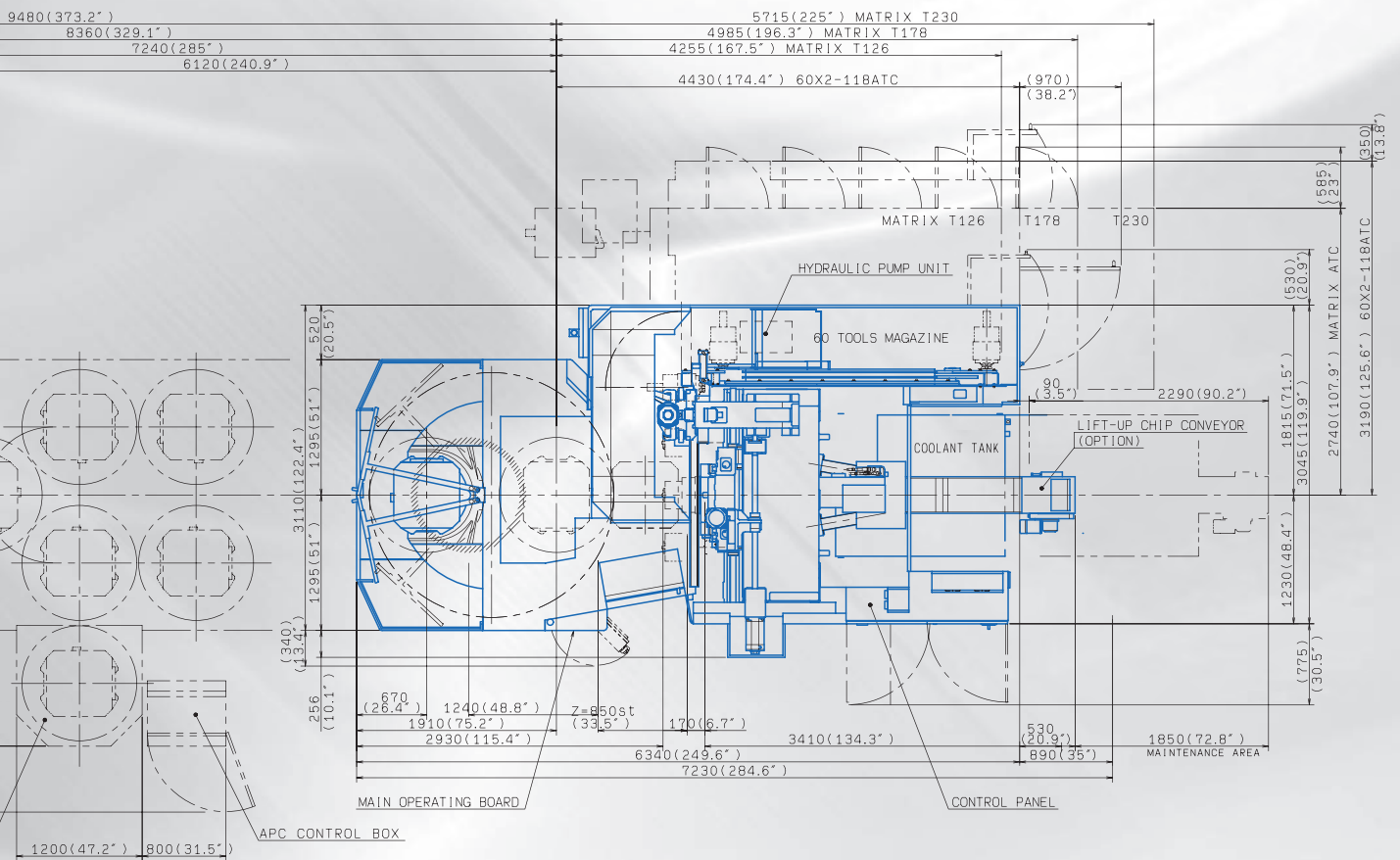

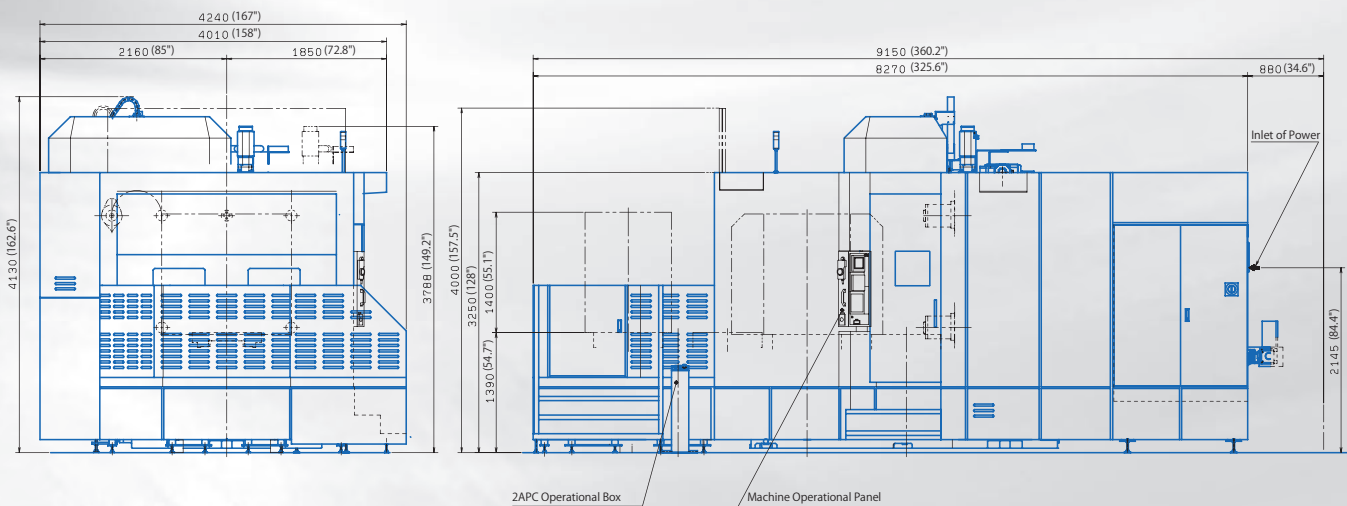
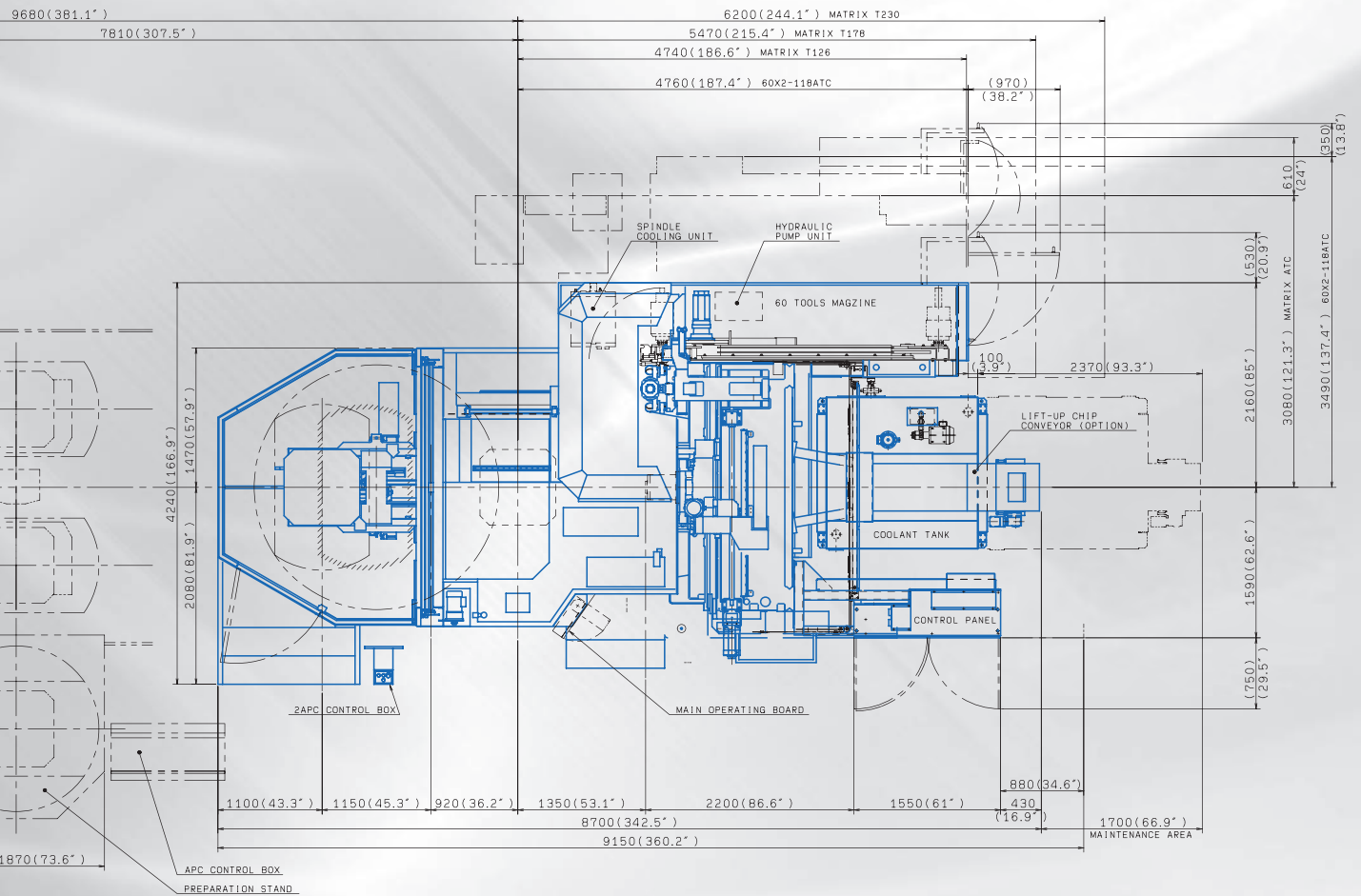

MACHINE SPECIFICATIONS

ITEM	NX 5000		
	Metric	Inch	
TRAVEL & WORK CAPACITY	X axis travel (saddle side to side)	800 mm	31.5 "
	Y axis travel (spindle head up and down)	750 mm	29.5 "
	Z axis travel (table front and rear)	830 mm	32.7 "
	Spindle center line to pallet surface	80 ~ 830	3.15 ~ 32.7"
	Spindle nose to table center line	99 ~ 950	3.9 ~ 37.4 "
TABLE	Table working surface	500 × 500 mm	19.7 × 19.7 "
	Table increments	1° [0.001°]	1° [0.001°]
	Maximum mass on pallet	600 kg	1320 lbs
SPINDLE	Spindle drive motor	AC 30 / 25 kW	AC 40 / 34 HP
	Spindle speeds	10000 min ⁻¹	10000 rpm
	Spindle max. torque	420 N·m	310 ft·lbs
	Spindle taper	No.50	No.50
FEEDRATE	Rapid traverse X axis	50 [61] m/min	1968 [2400] ipm
	Y axis	50 [61] m/min	1968 [2400] ipm
	Z axis	50 [61] m/min	1968 [2400] ipm
	Cutting X - Y - Z	1 ~ 40000 mm/min	0.04 ~ 1575 ipm
	Table index speed / 1° table	25 min ⁻¹	25 rpm
	NC table	25 min ⁻¹	25 rpm
AUTOMATIC TOOL CHANGER (ATC)	Tool magazine capacity, Chain	62 [88/128]	62 [88/128]
	Matrix	[126/178/230/308]	[126/178/230/308]
	Tool selection	Short cut random	Short cut random
	Tool shank	BT50	CT50
	Maximum tool length	450 mm	17.7 "
	Maximum milling cutter dia.	120 mm	4.72 "
	Ditto adjacent pockets empty	230 mm	9.05 "
	Maximum tool mass (weight)	20 kg [30 kg]	44 lbs [66 lbs]
	Tool change time (tool to tool)	1.4 s	1.4 sec.
AUTOMATIC PALLET CHANGER (APC) ACCURACY	Type	Direct Turn	Direct Turn
	Number of pallets	2	2
	Positioning / full stroke X - Y - Z	± 0.0025 mm	± 0.00010 "
	Ditto with scales X - Y - Z	± 0.0020 mm	± 0.00008 "
	Repeatability X - Y - Z	± 0.0015 mm	± 0.00006 "
	Ditto with scales X - Y - Z	± 0.0010 mm	± 0.00004 "
GENERAL	Machine weight approx.	16000 kg	35200 lbs
	Machine space W / D	3442 / 5130 mm	135.5 / 201.0 "
	Ditto H	3406 mm	134.1 "
	Floor to table surface	1180 mm	46.5 "
	Power	67 kVA	67 kVA
	Control	Fanuc 30 iB (31 iB)	Fanuc 30 iB (31 iB)

	NX 7000		NX 9000	
	Metric	Inch	Metric	Inch
	1000 mm	39.4 "	1500 mm	59.1 "
	950 mm	37.4 "	1300 mm	51.2 "
	1049 mm	41.3 "	1150 mm	45.3 "
	80 ~ 1030 mm	3.15 ~ 40.6 "	80 ~ 1380 mm	3.15 ~ 54.3 "
	99 ~ 1148 mm	3.9 ~ 45.2 "	200 ~ 1350 mm	7.87 ~ 53.15 "
	630 × 630 mm	24.8 × 24.8 "	800 × 800 mm	31.5 × 31.5 "
	1° [0.001°]	1° [0.001°]	1° [0.001°]	1° [0.001°]
	1200 kg	2640 lbs	2000 kg [2500 kg]	4400 lbs [5500 lbs]
	AC 30 / 25 kW	AC 40 / 34 HP	AC 30 / 22 kW	AC 40 / 29.5 HP
	12000 min ⁻¹	12000 rpm	8000 min ⁻¹	8000 rpm
	420 N·m	310 ft·lbs	600 N·m	443 ft·lbs
	No.50	No.50	No.50	No.50
	60 m/min	2362 ipm	50 m/min	1968 ipm
	60 m/min	2362 ipm	50 m/min	1968 ipm
	60 m/min	2362 ipm	50 m/min	1968 ipm
	1 ~ 40000 mm/min	0.04 ~ 1575 ipm	1 ~ 40000 mm/min	0.04 ~ 1575 ipm
	20 min ⁻¹	20 rpm	12 min ⁻¹	12 rpm
	20 min ⁻¹	20 rpm	11.1 min ⁻¹	11.1 rpm
	60	60	60	60
	[126/178/230/308]	[126/178/230/308]	[126/178/230/308]	[126/178/230/308]
	Short cut random	Short cut random	Short cut random	Short cut random
	BT50	CT50	BT50	CT50
	550 mm	21.6 "	600 mm	23.6 "
	130 mm	5.1 "	130 mm	5.1 "
	260 mm	10.2 "	260 mm	10.2 "
	20 kg [30 kg]	44 lbs [66 lbs]	30 kg	66 lbs
	1.4 s	1.4 sec.	2.7 s	2.7 sec.
	Direct Turn	Direct Turn	Rotary shuttle	Rotary shuttle
	2	2	2	2
	± 0.0025 mm	± 0.00010 "	± 0.004 mm	± 0.00016 "
	± 0.0020 mm	± 0.00008 "	± 0.003 mm	± 0.00012 "
	± 0.0015 mm	± 0.00006 "	± 0.0015 mm	± 0.00006 "
	± 0.0010 mm	± 0.00004 "	± 0.0010 mm	± 0.00004 "
	20500 kg	45100 lbs	28000 kg	61600 lbs
	3366 / 7210 mm	132.5 / 283.9 "	4240 / 8270 mm	167 / 326 "
	3694 mm	145.4 "	4130 mm	162.6 "
	1310 mm	51.6 "	1370 mm	53.9 "
	87 kVA	87 kVA	76 kVA	76 kVA
	Fanuc 30 iB (31 iB)	Fanuc 30 iB (31 iB)	Fanuc 30 iB (31 iB)	Fanuc 30 iB (31 iB)

NOTE: [] means optional specifications

SOPHISTICATED SMART MACHINE TOOL UNMANNED SYSTEM



EXTENDED MULTI-FUNCTIONAL ICC CONTROLLER



SMART
MACHINE TOOL

N25 W23287 Paul Road, Pewaukee, WI 53072

TEL : 1-262-521-1100

FAX : 1-262-521-1244

www.smartmachinetool.com

The contents herein are subject to change without notice.
All non-metric values are converted from metric measurements.
Copy right ©2019 SMART MACHINE TOOL. All right reserved.

2021.11.30